



## EN29LV160C

### 16 Megabit (2048K x 8-bit / 1024K x 16-bit) Flash Memory

### Boot Sector Flash Memory, CMOS 3.0 Volt-only

#### FEATURES

- 3.0V, single power supply operation
  - Minimizes system level power requirements
- High performance
  - Access times as fast as 70 ns
- Low power consumption (typical values at 5 MHz)
  - 9 mA typical active read current
  - 20 mA typical program/erase current
  - Less than 1  $\mu$ A standby current
- Flexible Sector Architecture:
  - One 16-Kbyte, two 8-Kbyte, one 32-Kbyte, and thirty-one 64-Kbyte sectors (byte mode)
  - One 8-Kword, two 4-Kword, one 16-Kword and thirty-one 32-Kword sectors (word mode)
- Sector protection :
  - Hardware locking of sectors to prevent program or erase operations within individual sectors
  - Additionally, temporary Sector Group Unprotect allows code changes in previously locked sectors.
- Secured Silicon Sector
  - Provides a 128-words area for code or data that can be permanently protected.
  - Once this sector is protected, it is prohibited to program or erase within the sector again.
- High performance program/erase speed
  - Byte/Word program time: 8 $\mu$ s typical
  - Sector erase time: 100ms typical
  - Chip erase time: 4s typical
- JEDEC Standard program and erase commands
- JEDEC standard DATA# polling and toggle bits feature
- Single Sector and Chip Erase
- Sector Unprotect Mode
- Embedded Erase and Program Algorithms
- Erase Suspend / Resume modes:
  - Read and program another Sector during Erase Suspend Mode
- Triple-metal double-poly triple-well CMOS Flash Technology
- Low Vcc write inhibit  $\leq$  2.5V
- minimum 100K program/erase endurance cycle
- Package Options
  - 48-pin TSOP (Type 1)
  - 48 ball 6mm x 8mm TFBGA
- Industrial Temperature Range

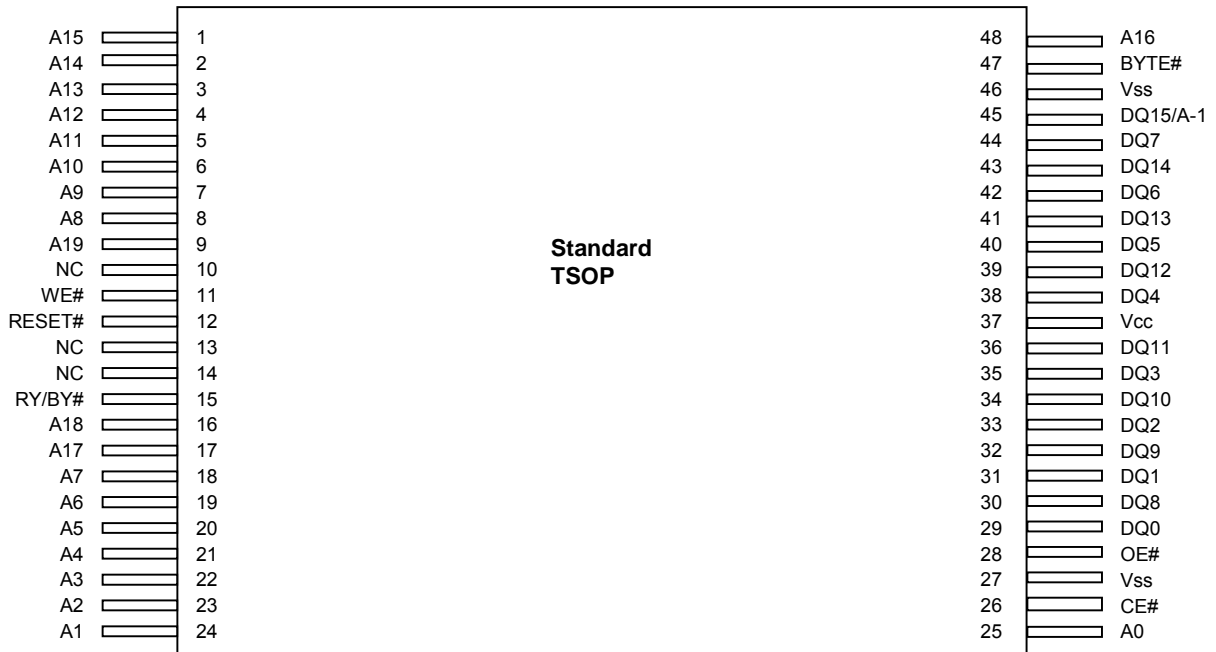
#### GENERAL DESCRIPTION

The EN29LV160C is a 16-Megabit, electrically erasable, read/write non-volatile flash memory, organized as 2,097,152 bytes or 1,048,576 words. Any byte can be programmed typically in 8 $\mu$ s. The EN29LV160C features 3.0V voltage read and write operation, with access times as fast as 70ns to eliminate the need for WAIT states in high-performance microprocessor systems.

The EN29LV160C has separate Output Enable (OE#), Chip Enable (CE#), and Write Enable (WE#) controls, which eliminate bus contention issues. This device is designed to allow either single Sector or full chip erase operation, where each Sector can be individually protected against program/erase operations or temporarily unprotected to erase or program. The device can sustain a minimum of 100K program/erase cycles on each Sector.



CONNECTION DIAGRAMS



48-Ball TFBGA

Top View, Balls Facing Down

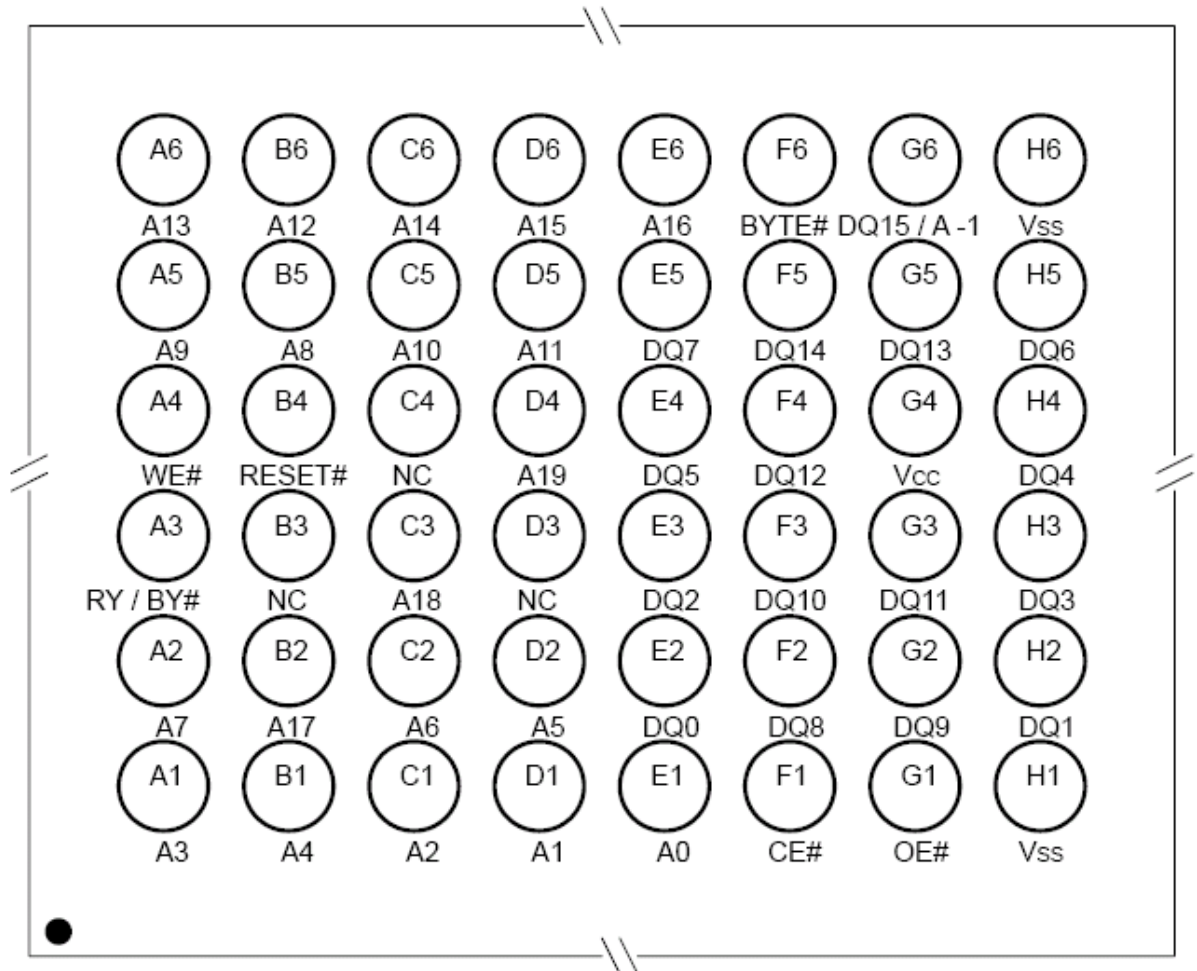
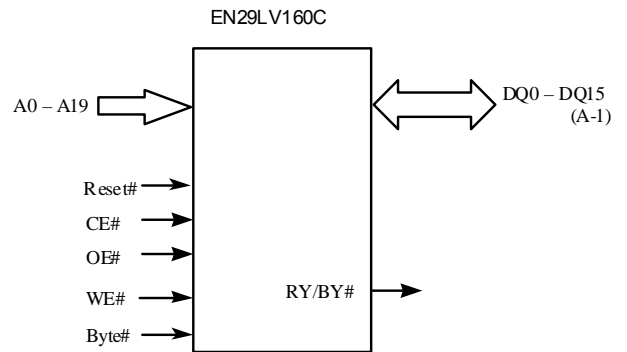




TABLE 1. PIN DESCRIPTION

Pin Name	Function
A0-A19	20 Addresses
DQ0-DQ14	15 Data Inputs/Outputs
DQ15 / A-1	DQ15 (data input/output, word mode), A-1 (LSB address input, byte mode)
CE#	Chip Enable
OE#	Output Enable
RESET#	Hardware Reset Pin
RY/BY#	Ready/Busy Output
WE#	Write Enable
Vcc	Supply Voltage (2.7-3.6V)
Vss	Ground
NC	Not Connected to anything
BYTE#	Byte/Word Mode

FIGURE 1. LOGIC DIAGRAM





**Table 2A. Top Boot Sector Address Tables (EN29LV160CT)**

Sector	A19	A18	A17	A16	A15	A14	A13	A12	Sector Size (Kbytes/ Kwords)	Address Range (in hexadecimal)	
										Byte mode (x8)	Word Mode (x16)
SA0	0	0	0	0	0	X	X	X	64/32	000000–00FFFF	00000–07FFF
SA1	0	0	0	0	1	X	X	X	64/32	010000–01FFFF	08000–0FFFF
SA2	0	0	0	1	0	X	X	X	64/32	020000–02FFFF	10000–17FFF
SA3	0	0	0	1	1	X	X	X	64/32	030000–03FFFF	18000–1FFFF
SA4	0	0	1	0	0	X	X	X	64/32	040000–04FFFF	20000–27FFF
SA5	0	0	1	0	1	X	X	X	64/32	050000–05FFFF	28000–2FFFF
SA6	0	0	1	1	0	X	X	X	64/32	060000–06FFFF	30000–37FFF
SA7	0	0	1	1	1	X	X	X	64/32	070000–07FFFF	38000–3FFFF
SA8	0	1	0	0	0	X	X	X	64/32	080000–08FFFF	40000–47FFF
SA9	0	1	0	0	1	X	X	X	64/32	090000–09FFFF	48000–4FFFF
SA10	0	1	0	1	0	X	X	X	64/32	0A0000–0AFFFF	50000–57FFF
SA11	0	1	0	1	1	X	X	X	64/32	0B0000–0BFFFF	58000–5FFFF
SA12	0	1	1	0	0	X	X	X	64/32	0C0000–0CFFFF	60000–67FFF
SA13	0	1	1	0	1	X	X	X	64/32	0D0000–0DFFFF	68000–6FFFF
SA14	0	1	1	1	0	X	X	X	64/32	0E0000–0EFFFF	70000–77FFF
SA15	0	1	1	1	1	X	X	X	64/32	0F0000–0FFFFF	78000–7FFFF
SA16	1	0	0	0	0	X	X	X	64/32	100000–10FFFF	80000–87FFF
SA17	1	0	0	0	1	X	X	X	64/32	110000–11FFFF	88000–8FFFF
SA18	1	0	0	1	0	X	X	X	64/32	120000–12FFFF	90000–97FFF
SA19	1	0	0	1	1	X	X	X	64/32	130000–13FFFF	98000–9FFFF
SA20	1	0	1	0	0	X	X	X	64/32	140000–14FFFF	A0000–A7FFF
SA21	1	0	1	0	1	X	X	X	64/32	150000–15FFFF	A8000–AFFFF
SA22	1	0	1	1	0	X	X	X	64/32	160000–16FFFF	B0000–B7FFF
SA23	1	0	1	1	1	X	X	X	64/32	170000–17FFFF	B8000–BFFFF
SA24	1	1	0	0	0	X	X	X	64/32	180000–18FFFF	C0000–C7FFF
SA25	1	1	0	0	1	X	X	X	64/32	190000–19FFFF	C8000–CFFFF
SA26	1	1	0	1	0	X	X	X	64/32	1A0000–1AFFFF	D0000–D7FFF
SA27	1	1	0	1	1	X	X	X	64/32	1B0000–1BFFFF	D8000–DFFFF
SA28	1	1	1	0	0	X	X	X	64/32	1C0000–1CFFFF	E0000–E7FFF
SA29	1	1	1	0	1	X	X	X	64/32	1D0000–1DFFFF	E8000–EFFFF
SA30	1	1	1	1	0	X	X	X	64/32	1E0000–1EFFFF	F0000–F7FFF
SA31	1	1	1	1	1	0	X	X	32/16	1F0000–1F7FFF	F8000–FBFFF
SA32	1	1	1	1	1	1	0	0	8/4	1F8000–1F9FFF	FC000–FCFFF
SA33	1	1	1	1	1	1	0	1	8/4	1FA000–1FBFFF	FD000–FDFFF
SA34	1	1	1	1	1	1	1	X	16/8	1FC000–1FFFFF	FE000–FFFFF

**Table 2B. Top Boot Security Sector Address (EN29LV160CT)**

Sector Address A19 ~ A12	Sector Size (bytes / words)	Address Range (h) Byte mode (x8)	Address Range (h) Word Mode (x16)
11111111	256 / 128	1FFF00–1FFFFFF	0FFF80–0FFFFFF



**Table 2C. Bottom Boot Sector Address Tables (EN29LV160CB)**

Sector	A19	A18	A17	A16	A15	A14	A13	A12	Sector Size (Kbytes/ Kwords)	Address Range (in hexadecimal)	
										Byte mode (x8)	Word Mode (x16)
SA0	0	0	0	0	0	0	0	X	16/8	000000–003FFF	00000–01FFF
SA1	0	0	0	0	0	0	1	0	8/4	004000–005FFF	02000–02FFF
SA2	0	0	0	0	0	0	1	1	8/4	006000–007FFF	03000–03FFF
SA3	0	0	0	0	0	1	X	X	32/16	008000–00FFFF	04000–07FFF
SA4	0	0	0	0	1	X	X	X	64/32	010000–01FFFF	08000–0FFFF
SA5	0	0	0	1	0	X	X	X	64/32	020000–02FFFF	10000–17FFF
SA6	0	0	0	1	1	X	X	X	64/32	030000–03FFFF	18000–1FFFF
SA7	0	0	1	0	0	X	X	X	64/32	040000–04FFFF	20000–27FFF
SA8	0	0	1	0	1	X	X	X	64/32	050000–05FFFF	28000–2FFFF
SA9	0	0	1	1	0	X	X	X	64/32	060000–06FFFF	30000–37FFF
SA10	0	0	1	1	1	X	X	X	64/32	070000–07FFFF	38000–3FFFF
SA11	0	1	0	0	0	X	X	X	64/32	080000–08FFFF	40000–47FFF
SA12	0	1	0	0	1	X	X	X	64/32	090000–09FFFF	48000–4FFFF
SA13	0	1	0	1	0	X	X	X	64/32	0A0000–0AFFFF	50000–57FFF
SA14	0	1	0	1	1	X	X	X	64/32	0B0000–0BFFFF	58000–5FFFF
SA15	0	1	1	0	0	X	X	X	64/32	0C0000–0CFFFF	60000–67FFF
SA16	0	1	1	0	1	X	X	X	64/32	0D0000–0DFFFF	68000–6FFFF
SA17	0	1	1	1	0	X	X	X	64/32	0E0000–0EFFFF	70000–77FFF
SA18	0	1	1	1	1	X	X	X	64/32	0F0000–0FFFFF	78000–7FFFF
SA19	1	0	0	0	0	X	X	X	64/32	100000–10FFFF	80000–87FFF
SA20	1	0	0	0	1	X	X	X	64/32	110000–11FFFF	88000–8FFFF
SA21	1	0	0	1	0	X	X	X	64/32	120000–12FFFF	90000–97FFF
SA22	1	0	0	1	1	X	X	X	64/32	130000–13FFFF	98000–9FFFF
SA23	1	0	1	0	0	X	X	X	64/32	140000–14FFFF	A0000–A7FFF
SA24	1	0	1	0	1	X	X	X	64/32	150000–15FFFF	A8000–AFFFF
SA25	1	0	1	1	0	X	X	X	64/32	160000–16FFFF	B0000–B7FFF
SA26	1	0	1	1	1	X	X	X	64/32	170000–17FFFF	B8000–BFFFF
SA27	1	1	0	0	0	X	X	X	64/32	180000–18FFFF	C0000–C7FFF
SA28	1	1	0	0	1	X	X	X	64/32	190000–19FFFF	C8000–CFFFF
SA29	1	1	0	1	0	X	X	X	64/32	1A0000–1AFFFF	D0000–D7FFF
SA30	1	1	0	1	1	X	X	X	64/32	1B0000–1BFFFF	D8000–DFFFF
SA31	1	1	1	0	0	X	X	X	64/32	1C0000–1CFFFF	E0000–E7FFF
SA32	1	1	1	0	1	X	X	X	64/32	1D0000–1DFFFF	E8000–EFFFF
SA33	1	1	1	1	0	X	X	X	64/32	1E0000–1EFFFF	F0000–F7FFF
SA34	1	1	1	1	1	X	X	X	64/32	1F0000–1FFFFF	F8000–FFFFF

**Table 2D. Bottom Boot Security Sector Address (EN29LV160CB)**

Sector Address A19 ~ A12	Sector Size (bytes / words)	Address Range (h) Byte mode (x8)	Address Range (h) Word Mode (x16)
00000000	256 / 128	000000–0000FF	000000–00007F



PRODUCT SELECTOR GUIDE

Product Number	EN29LV160C
Speed	-70
Max Access Time, ns ( $t_{acc}$ )	70
Max CE# Access, ns ( $t_{ce}$ )	70
Max OE# Access, ns ( $t_{oe}$ )	30

BLOCK DIAGRAM

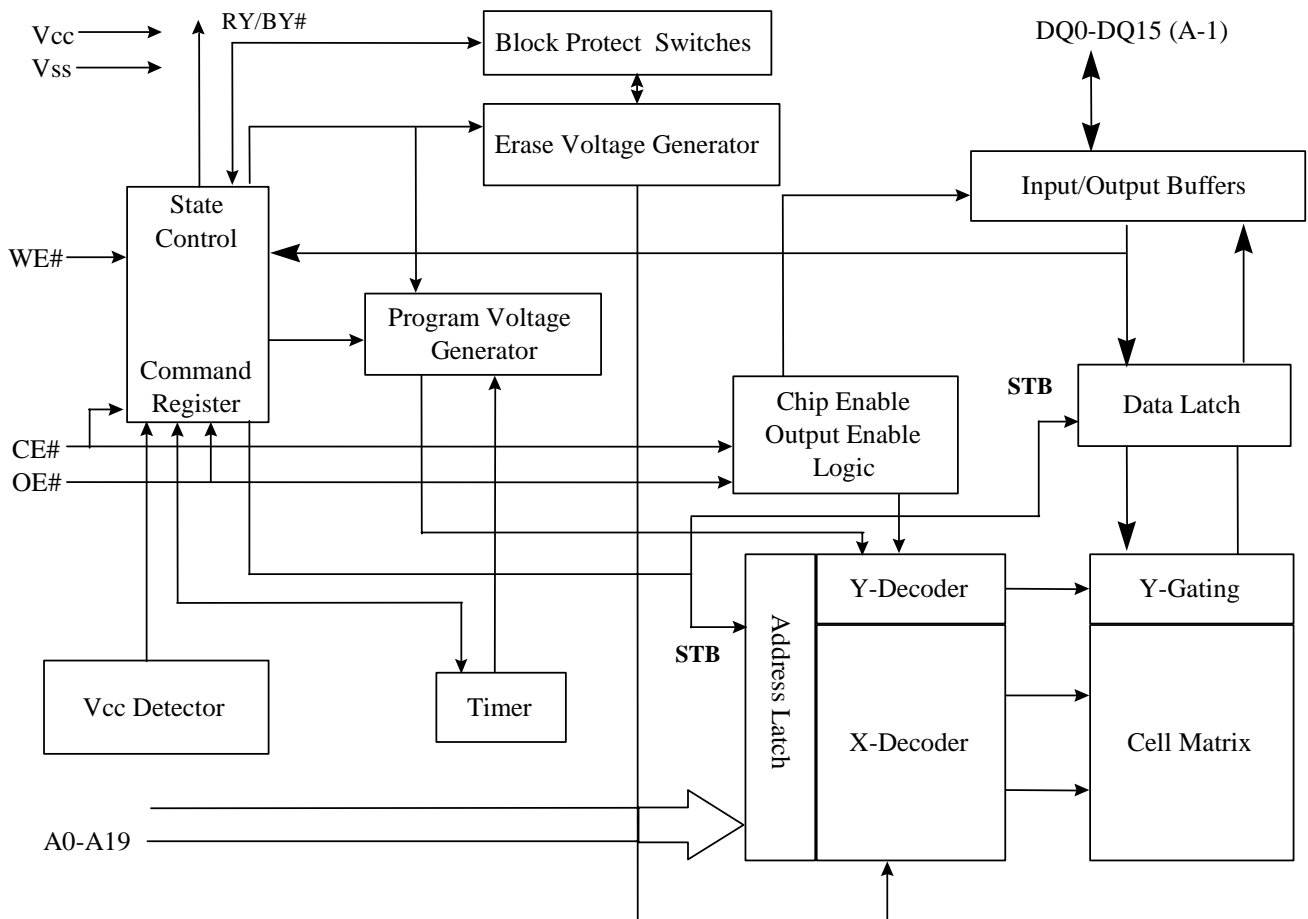




TABLE 3. OPERATING MODES

16M FLASH USER MODE TABLE

Operation	CE#	OE#	WE#	Reset#	A0-A19	DQ0-DQ7	DQ8-DQ15	
							Byte# = V <sub>IH</sub>	Byte# = V <sub>IL</sub>
Read	L	L	H	H	A <sub>IN</sub>	D <sub>OUT</sub>	D <sub>OUT</sub>	High-Z
Write	L	H	L	H	A <sub>IN</sub>	D <sub>IN</sub>	D <sub>IN</sub>	High-Z
CMOS Standby	V <sub>CC</sub> ± 0.3V	X	X	V <sub>CC</sub> ± 0.3V	X	High-Z	High-Z	High-Z
TTL Standby	H	X	X	H	X	High-Z	High-Z	High-Z
Output Disable	L	H	H	H	X	High-Z	High-Z	High-Z
Hardware Reset	X	X	X	L	X	High-Z	High-Z	High-Z
Temporary Sector Unprotect	X	X	X	V <sub>ID</sub>	A <sub>IN</sub>	D <sub>IN</sub>	D <sub>IN</sub>	X

## Notes:

L=logic low= V<sub>IL</sub>, H=Logic High= V<sub>IH</sub>, V<sub>ID</sub> = 9 ± 0.5V, X=Don't Care (either L or H, but not floating!),D<sub>IN</sub>=Data In, D<sub>OUT</sub>=Data Out, A<sub>IN</sub>=Address In



TABLE 4. Autoselect Codes (Using High Voltage, V<sub>ID</sub>)

**16M FLASH MANUFACTURER/DEVICE ID TABLE**

Description		CE#	OE#	WE#	A19 to A12	A11 to A10	A9 <sup>2</sup>	A8	A7	A6	A5 to A2	A1	A0	DQ8 to DQ15	DQ7 to DQ0
Manufacturer ID: Eon		L	L	H	X	X	V <sub>ID</sub>	L H <sup>1</sup>	X	L	X	L	L	X	7FH 1CH
Device ID (top boot block)	Word	L	L	H	X	X	V <sub>ID</sub>	X	X	L	X	L	H	22h	C4H
	Byte	L	L	H										X	C4H
Device ID (bottom boot block)	Word	L	L	H	X	X	V <sub>ID</sub>	X	X	L	X	L	H	22h	49H
	Byte	L	L	H										X	49H
Sector Protection Verification		L	L	H	SA	X	V <sub>ID</sub>	X	X	L	X	H	L	X	01h (Protected)
														X	00h (Unprotected)

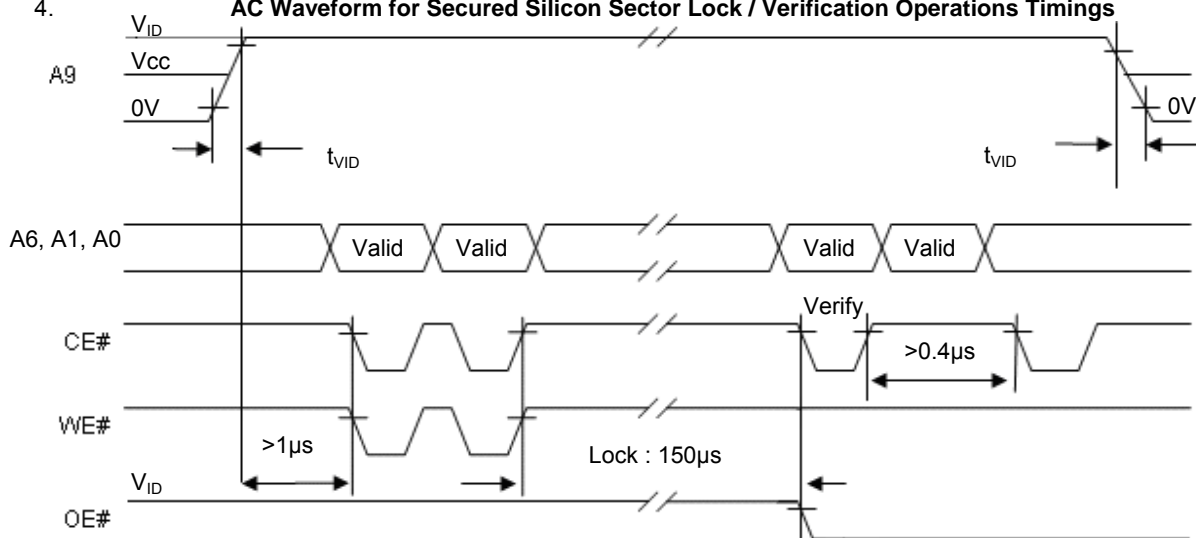
**16M FLASH SECURED SILICON SECTOR TABLE<sup>3</sup>**

Description		CE#	OE#	WE#	A21 to A12	A11 to A10	A9 <sup>2</sup>	A8	A7	A6	A5 to A2	A1	A0	DQ8 to DQ15	DQ7 to DQ0
Secured Silicon Sector Lock <sup>4</sup>		L	V <sub>ID</sub>		X	X	V <sub>ID</sub>	X	X	L	X	H	L	X	X
Secured Silicon Sector Lock Bit Verification (DQ0) <sup>4</sup>		L	L	H	X	X	V <sub>ID</sub>	X	X	L	X	H	L	X	X1h (Locked) X0h (Unlocked)

L=logic low= V<sub>IL</sub>, H=Logic High= V<sub>IH</sub>, V<sub>ID</sub> = 9 ± 0.5V, X=Don't Care (either L or H, but not floating!), SA=Sector Addresses

**Note:**

- A8 = H is recommended for Manufacturing ID check. If a manufacturing ID is read with A8=L, the chip will output a configuration code 7Fh.
- A9 = V<sub>ID</sub> is for HV A9 Autoselect mode only. A9 must be ≤ V<sub>CC</sub> (CMOS logic level) for Command Autoselect Mode.
- 16M FLASH SECURED SILICON SECTOR TABLE is valid only in Secured Silicon Sector.
- AC Waveform for Secured Silicon Sector Lock / Verification Operations Timings





## **USER MODE DEFINITIONS**

### **Word / Byte Configuration**

The signal set on the BYTE# Pin controls whether the device data I/O pins DQ15-DQ0 operate in the byte or word configuration. When the Byte# Pin is set at logic '1', then the device is in word configuration, DQ15-DQ0 are active and are controlled by CE# and OE#.

On the other hand, if the Byte# Pin is set at logic '0', then the device is in byte configuration, and only data I/O pins DQ0-DQ7 are active and controlled by CE# and OE#. The data I/O pins DQ8-DQ14 are tri-stated, and the DQ15 pin is used as an input for the LSB (A-1) address function.

### **Standby Mode**

The EN29LV160C has a CMOS-compatible standby mode, which reduces the current to < 1 $\mu$ A (typical). It is placed in CMOS-compatible standby when the CE# pin is at  $V_{CC} \pm 0.5$ . RESET# and BYTE# pin must also be at CMOS input levels. The device also has a TTL-compatible standby mode, which reduces the maximum  $V_{CC}$  current to < 1mA. It is placed in TTL-compatible standby when the CE# pin is at  $V_{IH}$ . When in standby modes, the outputs are in a high-impedance state independent of the OE# input.

### **Read Mode**

The device is automatically set to reading array data after device power-up. No commands are required to retrieve data. The device is also ready to read array data after completing an Embedded Program or Embedded Erase algorithm.

After the device accepts an Erase Suspend command, the device enters the Erase Suspend mode. The system can read array data using the standard read timings, except that if it reads at an address within erase-suspended sectors, the device outputs status data. After completing a programming operation in the Erase Suspend mode, the system may once again read array data with the same exception. See "Erase Suspend/Erase Resume Commands" for more additional information.

The system must issue the reset command to re-enable the device for reading array data if DQ5 goes high, or while in the autoselect mode. See the "Reset Command" additional details.

### **Output Disable Mode**

When the CE# or OE# pin is at a logic high level ( $V_{IH}$ ), the output from the EN29LV160C is disabled. The output pins are placed in a high impedance state.

### **Auto Select Identification Mode**

The autoselect mode provides manufacturer and device identification, and sector protection verification, through identifier codes output on DQ15-DQ0. This mode is primarily intended for programming equipment to automatically match a device to be programmed with its corresponding programming algorithm. However, the autoselect codes can also be accessed in-system through the command register.

When using programming equipment, the autoselect mode requires  $V_{ID}$  (8.5 V to 9.5 V) on address pin A9. Address pins A6, A1, and A0 must be as shown in Autoselect Codes table. In addition, when verifying sector protection, the sector address must appear on the appropriate highest order address bits. Refer to the corresponding Sector Address Tables. The Command Definitions table shows the remaining address bits that are don't-care. When all necessary bits have been set as required, the programming equipment may then read the corresponding identifier code on DQ15-DQ0.

To access the autoselect codes in-system; the host system can issue the autoselect command via the command register, as shown in the Command Definitions table. This method does not require  $V_{ID}$ . See "Command Definitions" for details on using the autoselect mode.



### Write Mode

Programming is a four-bus-cycle operation. The program command sequence is initiated by writing two unlock write cycles, followed by the program set-up command. The program address and data are written next, which in turn initiate the Embedded Program algorithm. The system is not required to provide further controls or timings. The device automatically provides internally generated program pulses and verifies the programmed cell margin. The Command Definitions in Table 5 show the address and data requirements for the byte program command sequence.

When the Embedded Program algorithm is complete, the device then returns to reading array data and addresses are no longer latched. The system can determine the status of the program operation by using DQ7 or DQ6. See "Write Operation Status" for information on these status bits.

Any commands written to the device during the Embedded Program Algorithm are ignored.

Programming is allowed in any sequence and across sector boundaries. **A bit cannot be programmed from a "0" back to a "1"**. Attempting to do so may halt the operation and set DQ5 to "1", or cause the Data# Polling algorithm to indicate the operation was successful. However, a succeeding read will show that the data is still "0". Only erase operations can convert a "0" to a "1".

### Sector Protection/Unprotection

The hardware sector protection feature disables both program and erase operations in any sector. The hardware sector unprotection feature re-enables both program and erase operations in previously protected sectors.

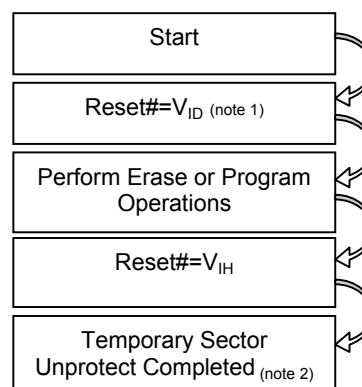
There are two methods to enabling this hardware protection circuitry. The first one requires only that the RESET# pin be at V<sub>ID</sub> and then standard microprocessor timings can be used to enable or disable this feature. See Flowchart 7a and 7b for the algorithm and Figure 12 for the timings. When doing Sector Unprotect, all the other sectors should be protected first.

The second method is meant for programming equipment. This method requires V<sub>ID</sub> be applied to both OE# and A9 pin and non-standard microprocessor timings are used. This method is described in a separate document called EN29LV160C Supplement, which can be obtained by contacting a representative of Eon Silicon Solution, Inc.

### Temporary Sector Unprotect

This feature allows temporary unprotection of previously protected sector groups to change data while in-system. The Sector Unprotect mode is activated by setting the RESET# pin to V<sub>ID</sub>. During this mode, formerly protected sectors can be programmed or erased by simply selecting the sector addresses. Once is removed from the RESET# pin, all the previously protected sectors are protected again. See accompanying figure and timing diagrams for more details.

- Notes:
1. All protected sectors unprotected.
  2. Previously protected sectors protected again.



**COMMON FLASH INTERFACE (CFI)**

The common flash interface (CFI) specification outlines device and host systems software interrogation handshake, which allows specific vendor-specified software algorithms to be used for entire families of devices. Software support can then be device-independent, JEDEC ID-independent, and forward- and backward-compatible for the specified flash device families. Flash vendors can standardize their existing interfaces for long-term compatibility.

This device enters the CFI Query mode when the system writes the CFI Query command, 98h, to address 55h in word mode (or address AAh in byte mode), any time the device is ready to read array data.

The system can read CFI information at the addresses given in Tables 5-8. In word mode, the upper address bits (A7–MSB) must be all zeros. To terminate reading CFI data, the system must write the reset command.

The system can also write the CFI query command when the device is in the autoselect mode. The device enters the CFI query mode and the system can read CFI data at the addresses given in Tables 5–8. The system must write the reset command to return the device to the autoselect mode.

**Table 5. CFI Query Identification String**

Addresses (Word Mode)	Addresses (Byte Mode)	Data	Description
10h 11h 12h	20h 22h 24h	0051h 0052h 0059h	Query Unique ASCII string "QRY"
13h 14h	26h 28h	0002h 0000h	Primary OEM Command Set
15h 16h	2Ah 2Ch	0040h 0000h	Address for Primary Extended Table
17h 18h	2Eh 30h	0000h 0000h	Alternate OEM Command set (00h = none exists)
19h 1Ah	32h 34h	0000h 0000h	Address for Alternate OEM Extended Table (00h = none exists)

**Table 6. System Interface String**

Addresses (Word Mode)	Addresses (Byte Mode)	Data	Description
1Bh	36h	0027h	Vcc Min (write/erase) D7-D4: volt, D3 –D0: 100 millivolt
1Ch	38h	0036h	Vcc Max (write/erase) D7-D4: volt, D3 –D0: 100 millivolt
1Dh	3Ah	0000h	Vpp Min. voltage (00h = no Vpp pin present)
1Eh	3Ch	0000h	Vpp Max. voltage (00h = no Vpp pin present)
1Fh	3Eh	0004h	Typical timeout per single byte/word write 2 <sup>N</sup> s
20h	40h	0000h	Typical timeout for Min, size buffer write 2 <sup>N</sup> s (00h = not supported)
21h	42h	000Ah	Typical timeout per individual block erase 2 <sup>N</sup> ms
22h	44h	0000h	Typical timeout for full chip erase 2 <sup>N</sup> ms (00h = not supported)
23h	46h	0005h	Max. timeout for byte/word write 2 <sup>N</sup> times typical
24h	48h	0000h	Max. timeout for buffer write 2 <sup>N</sup> times typical
25h	4Ah	0004h	Max. timeout per individual block erase 2 <sup>N</sup> times typical
26h	4Ch	0000h	Max timeout for full chip erase 2 <sup>N</sup> times typical (00h = not supported)



Table 7. Device Geometry Definition

Addresses (Word mode)	Addresses (Byte Mode)	Data	Description
27h	4Eh	0015h	Device Size = 2 <sup>N</sup> byte
28h	50h	0002h	Flash Device Interface description (refer to CFI publication 100)
29h	52h	0000h	
2Ah	54h	0000h	Max. number of byte in multi-byte write = 2 <sup>N</sup> (00h = not supported)
2Bh	56h	0000h	
2Ch	58h	0004h	Number of Erase Block Regions within device
2Dh	5Ah	0000h	Erase Block Region 1 Information (refer to the CFI specification of CFI publication 100)
2Eh	5Ch	0000h	
2Fh	5Eh	0040h	
30h	60h	0000h	
31h	62h	0001h	Erase Block Region 2 Information
32h	64h	0000h	
33h	66h	0020h	
34h	68h	0000h	
35h	6Ah	0000h	Erase Block Region 3 Information
36h	6Ch	0000h	
37h	6Eh	0080h	
38h	70h	0000h	
39h	72h	001Eh	Erase Block Region 4 Information
3Ah	74h	0000h	
3Bh	76h	0000h	
3Ch	78h	0001h	

Table 8. Primary Vendor-specific Extended Query

Addresses (Word Mode)	Addresses (Byte Mode)	Data	Description
40h	80h	0050h	Query-unique ASCII string "PRI"
41h	82h	0052h	
42h	84h	0049h	
43h	86h	0031h	Major version number, ASCII
44h	88h	0030h	Minor version number, ASCII
45h	8Ah	0000h	Address Sensitive Unlock 0 = Required, 1 = Not Required
46h	8Ch	0002h	Erase Suspend 0 = Not Supported, 1 = To Read Only, 2 = To Read & Write
47h	8Eh	0001h	Sector Protect 0 = Not Supported, X = Number of sectors in per group
48h	90h	0001h	Sector Temporary Unprotect 00 = Not Supported, 01 = Supported
49h	92h	0004h	Sector Protect/Unprotect scheme 01 = 29F040 mode, 02 = 29F016 mode, 03 = 29F400 mode, 04 = 29LV800A mode
4Ah	94h	0000h	Simultaneous Operation 00 = Not Supported, 01 = Supported
4Bh	96h	0000h	Burst Mode Type 00 = Not Supported, 01 = Supported
4Ch	98h	0000h	Page Mode Type 00 = Not Supported, 01 = 4 Word Page, 02 = 8 Word Page



## Hardware Data protection

The command sequence requirement of unlock cycles for programming or erasing provides data protection against inadvertent writes as seen in the Command Definitions table. Additionally, the following hardware data protection measures prevent accidental erasure or programming, which might otherwise be caused by false system level signals during Vcc power up and power down transitions, or from system noise.

### SECURED SILICON SECTOR

The EN29LV160C features an OTP memory region where the system may access through a command sequence to create a permanent part identification as so called Electronic Serial Number (ESN) in the device. Once this region is programmed and then locked by writing the Secured Silicon Sector Lock command (refer to Table 4 on page 9), any further modification in the region is impossible. The secured silicon sector is 128 words in length, and the Secured Silicon Sector Lock Bit (DQ0) is used to indicate whether the Secured Silicon Sector is locked or not.

The system accesses the Secured Silicon Sector through a command sequence (refer to "Enter Secured Silicon/ Exit Secured Silicon Sector command Sequence which are in Table 9 on page 15). After the system has written the Enter Secured Silicon Sector command sequence, it may read the Secured Silicon Sector by using the address normally occupied by the last sector SA34 (for EN29LV160CT) or first sector SA0 (for EN29LV160CB). Once entry the Secured Silicon Sector the operation of boot sectors and main sectors are disabled, the system must write Exit Secured Silicon Sector command sequence to return to read and write within the remainder of the array. This mode of operation continues until the system issues the Exit Secured Silicon Sector command sequence, or until power is removed from the device. On power-up, or following a hardware reset, the device reverts to sending command to sector SA0.

### Low V<sub>CC</sub> Write Inhibit

When Vcc is less than V<sub>LKO</sub>, the device does not accept any write cycles. This protects data during Vcc power up and power down. The command register and all internal program/erase circuits are disabled, and the device resets. Subsequent writes are ignored until Vcc is greater than V<sub>LKO</sub>. The system must provide the proper signals to the control pins to prevent unintentional writes when Vcc is greater than V<sub>LKO</sub>.

### Write Pulse "Glitch" protection

Noise pulses of less than 5 ns (typical) on OE#, CE# or WE# do not initiate a write cycle.

### Logical Inhibit

Write cycles are inhibited by holding any one of OE# = V<sub>IL</sub>, CE# = V<sub>IH</sub>, or WE# = V<sub>IH</sub>. To initiate a write cycle, CE# and WE# must be a logical zero while OE# is a logical one. If CE#, WE#, and OE# are all logical zero (not recommended usage), it will be considered a read.

### Power-up Write Inhibit

During power-up, the device automatically resets to READ mode and locks out write cycles. Even with CE# = V<sub>IL</sub>, WE# = V<sub>IL</sub> and OE# = V<sub>IH</sub>, the device will not accept commands on the rising edge of WE#.



## COMMAND DEFINITIONS

The operations of the EN29LV160C are selected by one or more commands written into the command register to perform Read/Reset Memory, Read ID, Read Sector Protection, Program, Sector Erase, Chip Erase, Erase Suspend and Erase Resume. Commands are made up of data sequences written at specific addresses via the command register. The sequences for the specified operation are defined in the Command Definitions table (Table 5). Incorrect addresses, incorrect data values or improper sequences will reset the device to Read Mode.

**Table 9. EN29LV160C Command Definitions**

Command Sequence			Cycles	Bus Cycles													
				1 <sup>st</sup> Write Cycle		2 <sup>nd</sup> Write Cycle		3 <sup>rd</sup> Write Cycle		4 <sup>th</sup> Write Cycle		5 <sup>th</sup> Write Cycle		6 <sup>th</sup> Write Cycle			
				Add	Data	Add	Data	Add	Data	Add	Data	Add	Data	Add	Data		
Read			1	RA	RD												
Reset			1	xxx	F0												
Autoselect	Manufacturer ID	Word	4	555	AA	2AA	55	555	90	000	7F						
		Byte		AAA		555		AAA		90	100	1C					
												000	7F				
												200	1C				
	Device ID Top Boot	Word	4	555	AA	2AA	55	555	90	x01	22C4						
		Byte		AAA		555		AAA		90	x02	C4					
	Device ID Bottom Boot	Word	4	555	AA	2AA	55	555	90	x01	2249						
		Byte		AAA		555		AAA		90	x02	49					
	Sector Protect Verify	Word	4	555	AA	2AA	55	555	90	(SA)	XX00						
													X02	XX01			
Byte		AAA		555		AAA		90		(SA)	00						
											X04	01					
									08								
Program	Word	4	555	AA	2AA	55	555	A0	PA	PD							
	Byte		AAA		555		AAA		A0	PA	PD						
Chip Erase	Word	6	555	AA	2AA	55	555	80	555	AA	2AA	55	555	10			
	Byte		AAA		555		AAA		80	AAA	AA		555		AAA		
Sector Erase	Word	6	555	AA	2AA	55	555	80	555	AA	2AA	55	SA	30			
	Byte		AAA		555		AAA		80	AAA	AA		555		555		
Erase Suspend			1	xxx	B0												
Erase Resume			1	xxx	30												
CFI Query	Word	1	55	98													
	Byte		AA														
Enter Secured Silicon Sector	Word	3	555	AA	2AA	55	555	88									
	Byte		AAA		555		AAA		88								
Exit Secured Silicon Sector	Word	4	555	AA	2AA	55	555	90	xxx	00							
	Byte		AAA		555		AAA		90	xxx	00						

Address and Data values indicated in hex

RA = Read Address: address of the memory location to be read. This is a read cycle.

RD = Read Data: data read from location RA during Read operation. This is a read cycle.

PA = Program Address: address of the memory location to be programmed. X = Don't-Care

PD = Program Data: data to be programmed at location PA

SA = Sector Address: address of the Sector to be erased or verified. Address bits A19-A12 uniquely select any Sector.



## Reading Array Data

The device is automatically set to reading array data after power up. No commands are required to retrieve data. The device is also ready to read array data after completing an Embedded Program or Embedded Erase algorithm.

Following an Erase Suspend command, Erase Suspend mode is entered. The system can read array data using the standard read timings, with the only difference in that if it reads at an address within erase suspended sectors, the device outputs status data. After completing a programming operation in the Erase Suspend mode, the system may once again read array data with the same exception.

The Reset command must be issued to re-enable the device for reading array data if DQ5 goes high, or while in the autoselect mode. See next section for details on Reset.

## Reset Command

Writing the reset command to the device resets the device to reading array data. Address bits are don't-care for this command.

The reset command may be written between the sequence cycles in an erase command sequence before erasing begins. This resets the device to reading array data. Once erasure begins, however, the device ignores reset commands until the operation is complete. The reset command may be written between the sequence cycles in a program command sequence before programming begins. This resets the device to reading array data (also applies to programming in Erase Suspend mode). Once programming begins, however, the device ignores reset commands until the operation is complete.

The reset command may be written between the sequence cycles in an autoselect command sequence. Once in the autoselect mode, the reset command must be written to return to reading array data (also applies to autoselect during Erase Suspend).

If DQ5 goes high during a program or erase operation, writing the reset command returns the device to reading array data (also applies during Erase Suspend).

## Autoselect Command Sequence

The autoselect command sequence allows the host system to access the manufacturer and device codes, and determine whether or not a sector is protected. The Command Definitions table shows the address and data requirements. This is an alternative to the method that requires  $V_{ID}$  on address bit A9 and is intended for PROM programmers.

Two unlock cycles followed by the autoselect command initiate the autoselect command sequence. Autoselect mode is then entered and the system may read at addresses shown in Table 4 any number of times, without needing another command sequence.

The system must write the reset command to exit the autoselect mode and return to reading array data.

## Word / Byte Programming Command

The device can be programmed by byte or by word, depending on the state of the Byte# Pin. Programming the EN29LV160C is performed by using a four-bus-cycle operation (two unlock write cycles followed by the Program Setup command and Program Data Write cycle). When the program command is executed, no additional CPU controls or timings are necessary. An internal timer terminates the program operation automatically. Address is latched on the falling edge of CE# or WE#, whichever is last; data is latched on the rising edge of CE# or WE#, whichever is first.

Programming status can be checked by sampling data on DQ7 (DATA# polling) or on DQ6 (toggle bit). When the program operation is successfully completed, the device returns to read mode and the user can read the data programmed to the device at that address. Note that data can not be programmed from a "0" to a "1". Only an erase operation can change a data from "0" to "1". When programming time



limit is exceeded, DQ5 will produce a logical “1” and a Reset command can return the device to Read mode.

## Chip Erase Command

Chip erase is a six-bus-cycle operation. The chip erase command sequence is initiated by writing two unlock cycles, followed by a set-up command. Two additional unlock write cycles are then followed by the chip erase command, which in turn invokes the Embedded Erase algorithm. The device does not require the system to preprogram prior to erase. The Embedded Erase algorithm automatically preprograms and verifies the entire memory for an all zero data pattern prior to electrical erase. The system is not required to provide any controls or timings during these operations. The Command Definitions table shows the address and data requirements for the chip erase command sequence.

Any commands written to the chip during the Embedded Chip Erase algorithm are ignored.

The system can determine the status of the erase operation by using DQ7, DQ6, or DQ2. See “Write Operation Status” for information on these status bits. When the Embedded Erase algorithm is complete, the device returns to reading array data and addresses are no longer latched.

Flowchart 4 illustrates the algorithm for the erase operation. See the Erase/Program Operations tables in “AC Characteristics” for parameters, and to the Chip/Sector Erase Operation Timings for timing waveforms.

## Sector Erase Command Sequence

Sector erase is a six bus cycle operation. The sector erase command sequence is initiated by writing two un-lock cycles, followed by a set-up command. Two additional unlock write cycles are then followed by the address of the sector to be erased, and the sector erase command. The Command Definitions table shows the address and data requirements for the sector erase command sequence.

Once the sector erase operation has begun, only the Erase Suspend command is valid. All other commands are ignored.

When the Embedded Erase algorithm is complete, the device returns to reading array data and addresses are no longer latched. The system can determine the status of the erase operation by using DQ7, DQ6, or DQ2. Refer to “Write Operation Status” for information on these status bits. Flowchart 4 illustrates the algorithm for the erase operation. Refer to the Erase/Program Operations tables in the “AC Characteristics” section for parameters, and to the Sector Erase Operations Timing diagram for timing waveforms.

## Erase Suspend / Resume Command

The Erase Suspend command allows the system to interrupt a sector erase operation and then read data from, or program data to, any sector not selected for erasure. This command is valid only during the sector erase operation. The Erase Suspend command is ignored if written during the chip erase operation or Embedded Program algorithm. Addresses are don't-cares when writing the Erase Suspend command.

When the Erase Suspend command is written during a sector erase operation, the device requires a maximum of 20  $\mu$ s to suspend the erase operation.

After the erase operation has been suspended, the system can read array data from or program data to any sector not selected for erasure. (The device “erase suspends” all sectors selected for erasure.) Normal read and write timings and command definitions apply. Reading at any address within erase-suspended sectors produces status data on DQ7–DQ0. The system can use DQ7, or DQ6 and DQ2 together, to determine if a sector is actively erasing or is erase-suspended. See “Write Operation Status” for information on these status bits.



After an erase-suspended program operation is complete, the system can once again read array data within non-suspended sectors. The system can determine the status of the program operation using the DQ7 or DQ6 status bits, just as in the standard program operation. See "Write Operation Status" for more information. The Autoselect command is not supported during Erase Suspend Mode.

The system must write the Erase Resume command (address bits are don't-care) to exit the erase suspend mode and continue the sector erase operation. Further writes of the Resume command are ignored. Another Erase Suspend command can be written after the device has resumed erasing.

## **WRITE OPERATION STATUS**

### **DQ7**

#### **DATA# Polling**

The EN29LV160C provides DATA# polling on DQ7 to indicate the status of the embedded operations. The DATA# polling feature is active during Byte Programming, Sector Erase, Chip Erase, and Erase Suspend. (See Table 10)

When the embedded Programming is in progress, an attempt to read the device will produce the complement of the data written to DQ7. Upon the completion of the Byte Programming, an attempt to read the device will produce the true data written to DQ7. For the Byte Programming, DATA# polling is valid after the rising edge of the fourth WE# or CE# pulse in the four-cycle sequence.

When the embedded Erase is in progress, an attempt to read the device will produce a "0" at the DQ7 output. Upon the completion of the embedded Erase, the device will produce the "1" at the DQ7 output during the read cycles. For Chip Erase, the DATA# polling is valid after the rising edge of the sixth WE# or CE# pulse in the six-cycle sequence. DATA# polling is valid after the last rising edge of the WE# or CE# pulse for chip erase or sector erase.

DATA# Polling must be performed at any address within a sector that is being programmed or erased and not a protected sector. Otherwise, DATA# polling may give an inaccurate result if the address used is in a protected sector.

Just prior to the completion of the embedded operations, DQ7 may change asynchronously when the output enable (OE#) is low. This means that the device is driving status information on DQ7 at one instant of time and valid data at the next instant of time. Depending on when the system samples the DQ7 output, it may read the status of valid data. Even if the device has completed the embedded operations and DQ7 has a valid data, the data output on DQ0-DQ6 may be still invalid. The valid data on DQ0-DQ7 will be read on the subsequent read attempts.

The flowchart for DATA# Polling (DQ7) is shown on Flowchart 5. The DATA# Polling (DQ7) timing diagram is shown in Figure 8.

### **RY/BY#: Ready/Busy**

The RY/BY# is a dedicated, open-drain output pin that indicates whether an Embedded Algorithm is in progress or completed. The RY/BY# status is valid after the rising edge of the final WE# pulse in the command sequence. Since RY/BY# is an open-drain output, several RY/BY# pins can be tied together in parallel with a pull-up resistor to Vcc.

In the output-low period, signifying Busy, the device is actively erasing or programming. This includes programming in the Erase Suspend mode. If the output is high, signifying the Ready, the device is ready to read array data (including during the Erase Suspend mode), or is in the standby mode.



## DQ6 Toggle Bit I

The EN29LV160C provides a “Toggle Bit” on DQ6 to indicate the status of the embedded programming and erase operations. (See Table 6)

During an embedded Program or Erase operation, successive attempts to read data from the device at any address (by active OE# or CE#) will result in DQ6 toggling between “zero” and “one”. Once the embedded Program or Erase operation is completed, DQ6 will stop toggling and valid data will be read on the next successive attempts. During embedded Programming, the Toggle Bit is valid after the rising edge of the fourth WE# pulse in the four-cycle sequence. During Erase operation, the Toggle Bit is valid after the rising edge of the sixth WE# pulse for sector erase or chip erase.

In embedded Programming, if the sector being written to is protected, DQ6 will toggle for about 2  $\mu$ s, then stop toggling without the data in the sector having changed. In Sector Erase or Chip Erase, if all selected sectors are protected, DQ6 will toggle for about 100  $\mu$ s. The chip will then return to the read mode without changing data in all protected sectors.

The flowchart for the Toggle Bit (DQ6) is shown in Flowchart 6. The Toggle Bit timing diagram is shown in Figure 9.

## DQ5 Exceeded Timing Limits

DQ5 indicates whether the program or erase time has exceeded a specified internal pulse count limit. Under these conditions DQ5 produces a “1.” This is a failure condition that indicates the program or erase cycle was not successfully completed. Since it is possible that DQ5 can become a 1 when the device has successfully completed its operation and has returned to read mode, the user must check again to see if the DQ6 is toggling after detecting a “1” on DQ5.

The DQ5 failure condition may appear if the system tries to program a “1” to a location that is previously programmed to “0.” **Only an erase operation can change a “0” back to a “1.”** Under this condition, the device halts the operation, and when the operation has exceeded the timing limits, DQ5 produces a “1.” Under both these conditions, the system must issue the reset command to return the device to reading array data.

## DQ3 Sector Erase Timer

After writing a sector erase command sequence, the output on DQ3 can be used to determine whether or not an erase operation has begun. (The sector erase timer does not apply to the chip erase command.) When sector erase starts, DQ3 switches from “0” to “1.” This device does not support multiple sector erase command sequences so it is not very meaningful since it immediately shows as a “1” after the first 30h command. Future devices may support this feature.

## DQ2 Erase Toggle Bit II

The “Toggle Bit” on DQ2, when used with DQ6, indicates whether a particular sector is actively erasing (that is, the Embedded Erase algorithm is in progress), or whether that sector is erase-suspended. Toggle Bit II is valid after the rising edge of the final WE# pulse in the command sequence. DQ2 toggles when the system reads at addresses within those sectors that have been selected for erasure. (The system may use either OE# or CE# to control the read cycles.) But DQ2 cannot distinguish whether the sector is actively erasing or is erase-suspended. DQ6, by comparison, indicates whether the device is actively erasing, or is in Erase Suspend, but cannot distinguish which sectors are selected for erasure. Thus, both status bits are required for sector and mode information. Refer to Table 5 to compare outputs for DQ2 and DQ6.

Flowchart 6 shows the toggle bit algorithm, and the section “DQ2: Toggle Bit” explains the algorithm. See also the “DQ6: Toggle Bit I” subsection. Refer to the Toggle Bit Timings figure for the toggle bit timing diagram. The DQ2 vs. DQ6 figure shows the differences between DQ2 and DQ6 in graphical form.

**Reading Toggle Bits DQ6/DQ2**

Refer to Flowchart 6 for the following discussion. Whenever the system initially begins reading toggle bit status, it must read DQ7–DQ0 at least twice in a row to determine whether a toggle bit is toggling. Typically, a system would note and store the value of the toggle bit after the first read. After the second read, the system would compare the new value of the toggle bit with the first. If the toggle bit is not toggling, the device has completed the program or erase operation. The system can read array data on DQ7–DQ0 on the following read cycle.

However, if after the initial two read cycles, the system determines that the toggle bit is still toggling, the system also should note whether the value of DQ5 is high (see the section on DQ5). If it is, the system should then determine again whether the toggle bit is toggling, since the toggle bit may have stopped toggling just as DQ5 went high. If the toggle bit is no longer toggling, the device has successfully completed the program or erase operation. If it is still toggling, the device did not complete the operation successfully, and the system must write the reset command to return to reading array data.

The remaining scenario is that the system initially determines that the toggle bit is toggling and DQ5 has not gone high. The system may continue to monitor the toggle bit and DQ5 through successive read cycles, determining the status as described in the previous paragraph. Alternatively, it may choose to perform other system tasks. In this case, the system must start at the beginning of the algorithm when it returns to determine the status of the operation (top of Flowchart 6).

**Write Operation Status**

Operation		DQ7	DQ6	DQ5	DQ3	DQ2	RY/BY#
Standard Mode	Embedded Program Algorithm	DQ7#	Toggle	0	N/A	No toggle	0
	Embedded Erase Algorithm	0	Toggle	0	1	Toggle	0
Erase Suspend Mode	Reading within Erase Suspended Sector	1	No Toggle	0	N/A	Toggle	1
	Reading within Non-Erase Suspended Sector	Data	Data	Data	Data	Data	1
	Erase-Suspend Program	DQ7#	Toggle	0	N/A	N/A	0



**Table 10. Status Register Bits**

DQ	Name	Logic Level	Definition
7	DATA# POLLING	'1'	Erase Complete or erase Sector in Erase suspend
		'0'	Erase On-Going
		DQ7	Program Complete or data of non-erase Sector during Erase Suspend
		DQ7#	Program On-Going
6	TOGGLE BIT	'-1-0-1-0-1-0-1-'	Erase or Program On-going
		DQ6	Read during Erase Suspend
		'-1-1-1-1-1-1-1-'	Erase Complete
5	TIME OUT BIT	'1'	Program or Erase Error
		'0'	Program or Erase On-going
3	ERASE TIME OUT BIT	'1'	Erase operation start
		'0'	Erase timeout period on-going
2	TOGGLE BIT	'-1-0-1-0-1-0-1-'	Chip Erase, Erase or Erase suspend on currently addressed Sector. (When DQ5=1, Erase Error due to currently addressed Sector. Program during Erase Suspend on-going at current address
		DQ2	Erase Suspend read on non Erase Suspend Sector

**Notes:**

DQ7 DATA# Polling: indicates the P/E status check during Program or Erase, and on completion before checking bits DQ5 for Program or Erase Success.

DQ6 Toggle Bit: remains at constant level when P/E operations are complete or erase suspend is acknowledged. Successive reads output complementary data on DQ6 while programming or Erase operation are on-going.

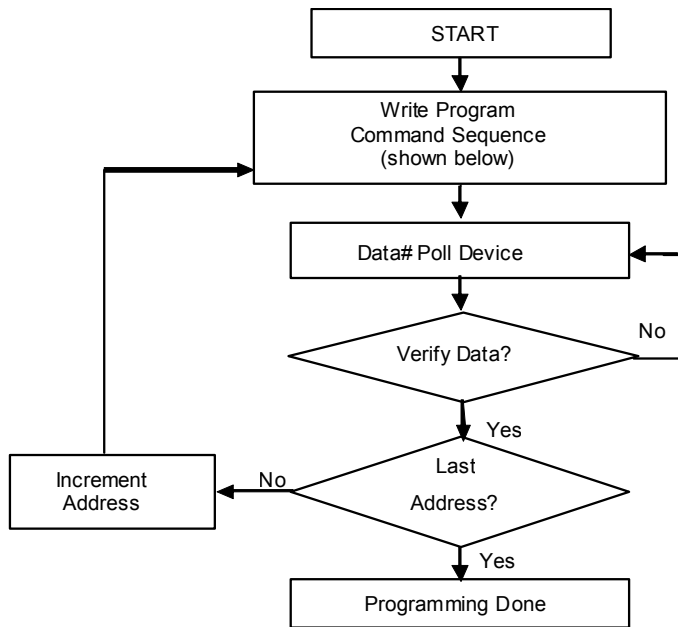
DQ5 Time Out Bit: set to "1" if failure in programming or erase

DQ3 Sector Erase Command Timeout Bit: Operation has started. Only possible command is Erase suspend (ES).

DQ2 Toggle Bit: indicates the Erase status and allows identification of the erased Sector.

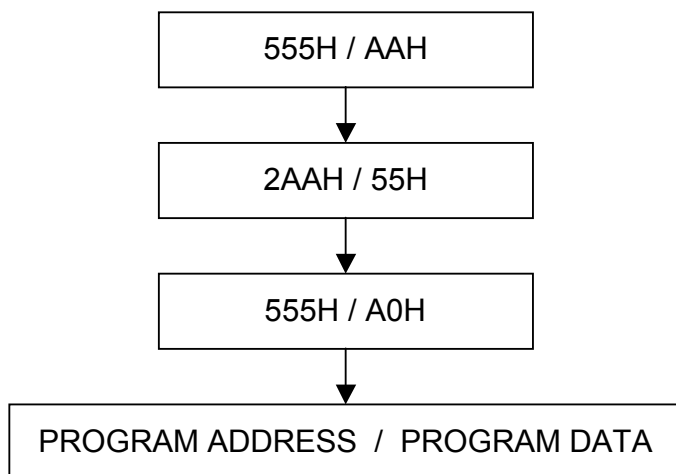
**EMBEDDED ALGORITHMS**

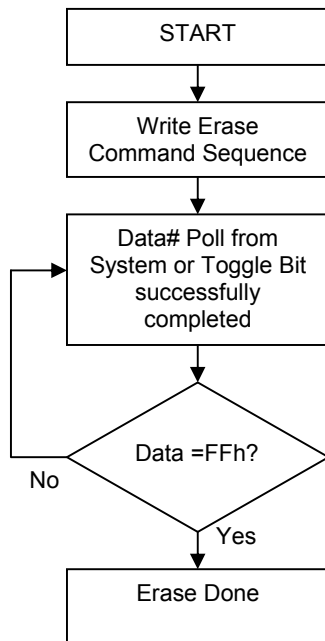
**Flowchart 1. Embedded Program**



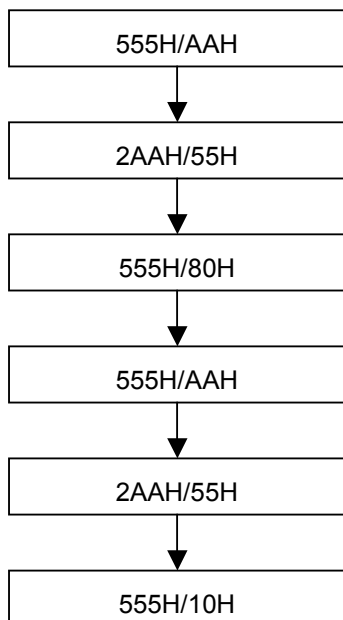
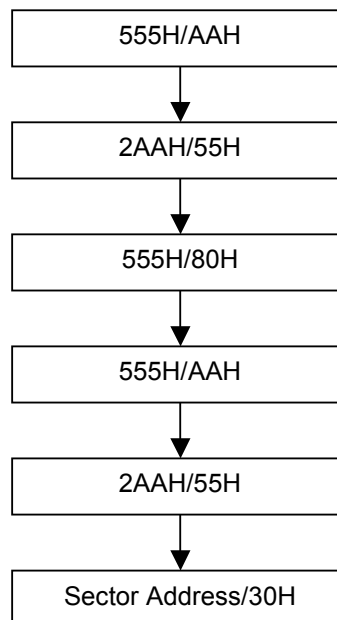
**Flowchart 2. Embedded Program Command Sequence**

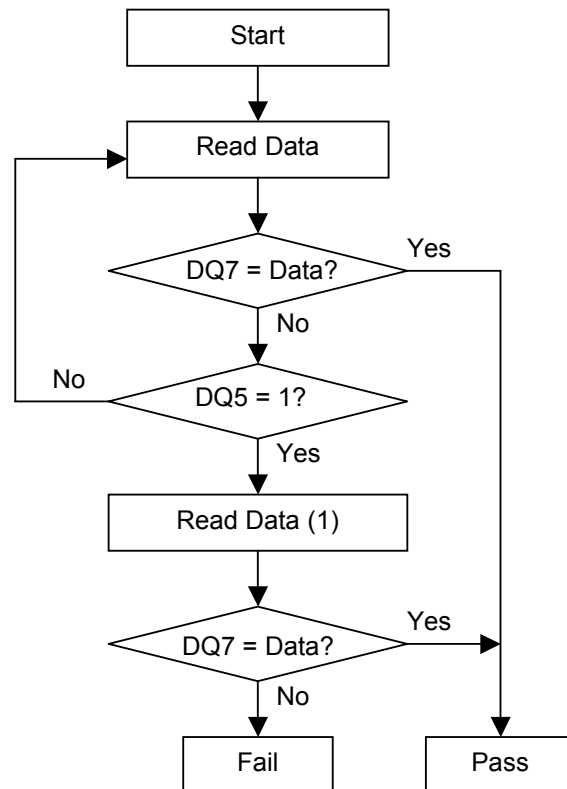
See the Command Definitions section for more information.



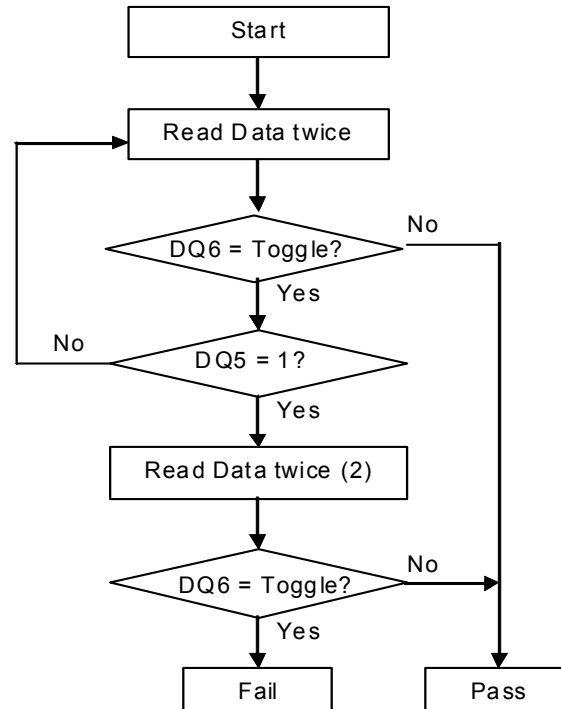
**Flowchart 3. Embedded Erase**

**Flowchart 4. Embedded Erase Command Sequence**

See the Command Definitions section for more information.

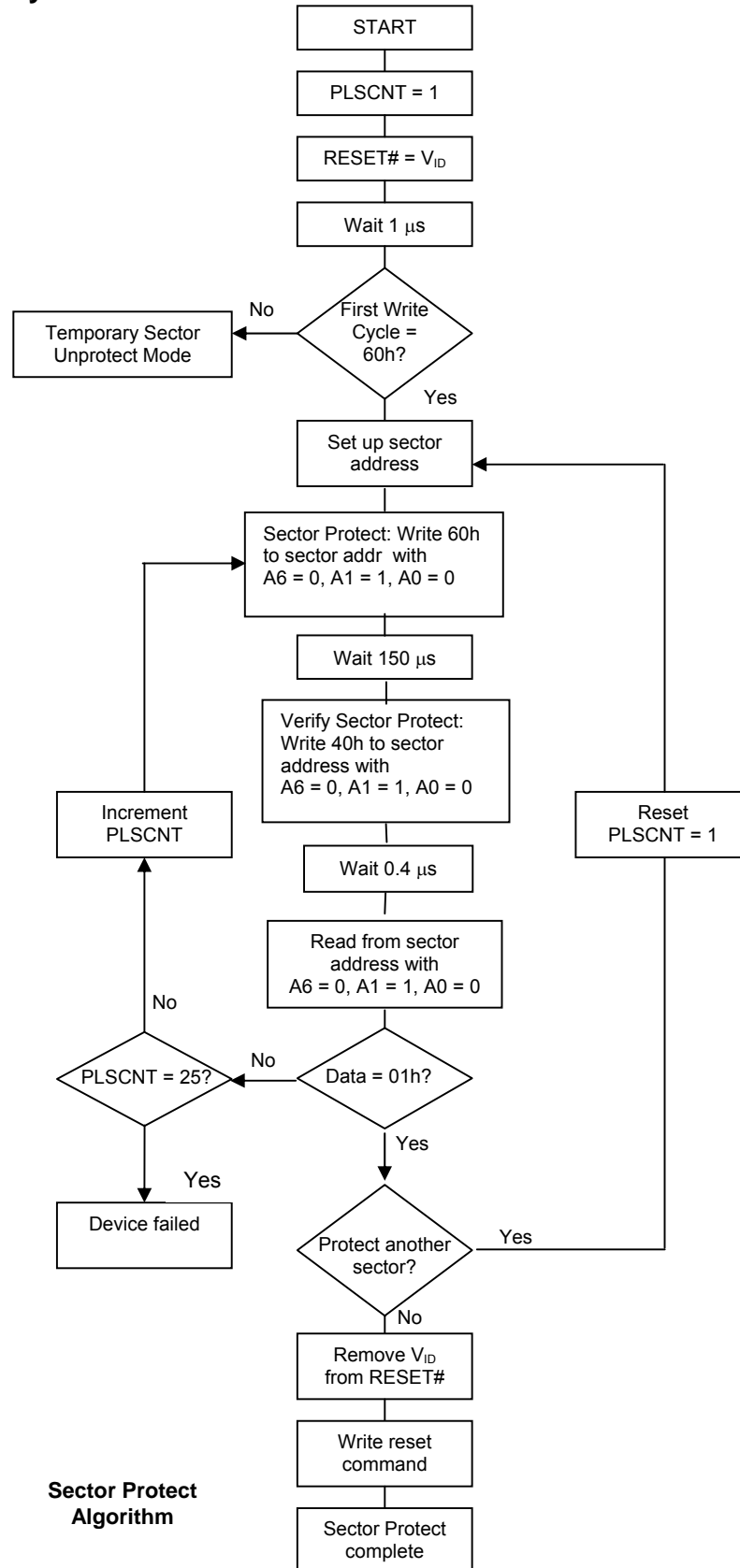
**Chip Erase**

**Sector Erase**


**Flowchart 5. DATA# Polling Algorithm**

**Notes:**

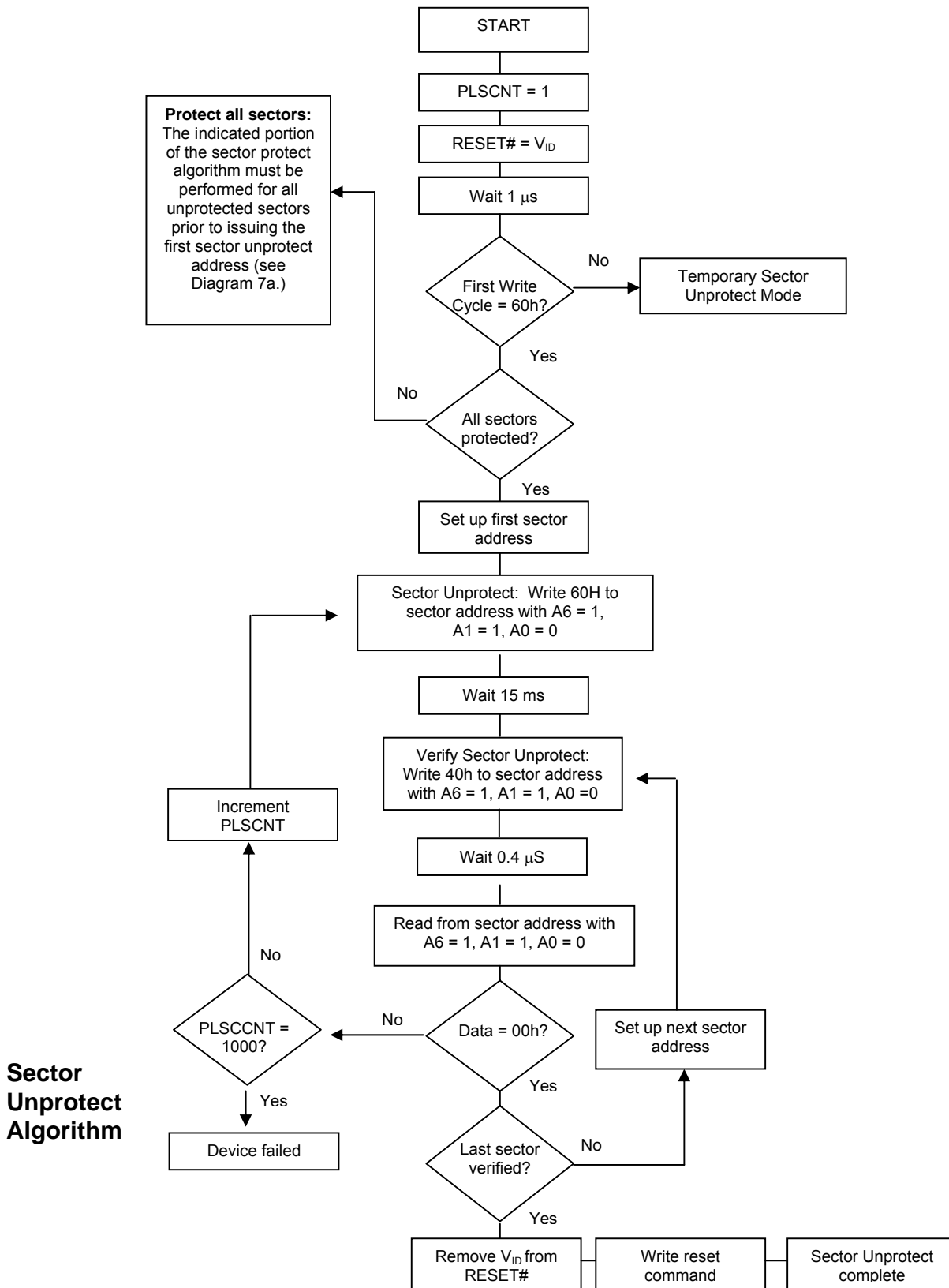
(1) This second read is necessary in case the first read was done at the exact instant when the status data was in transition.

**Flowchart 6. Toggle Bit Algorithm**

**Notes:**

(2) This second set of reads is necessary in case the first set of reads was done at the exact instant when the status data was in transition.

**Flowchart 7a. In-System Sector Protect Flowchart**


**Sector Protect Algorithm**

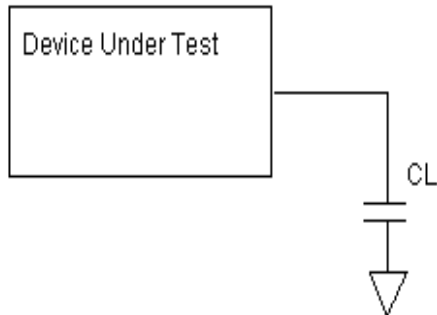
**Flowchart 7b. In-System Sector Unprotect Flowchart**


**Table 11. DC Characteristics**(T<sub>a</sub> = - 40°C to 85°C; V<sub>CC</sub> = 2.7-3.6V)

Symbol	Parameter	Test Conditions	Min	Typ	Max	Unit
I <sub>LI</sub>	Input Leakage Current	0V ≤ V <sub>IN</sub> ≤ V <sub>CC</sub>			±5	μA
I <sub>LO</sub>	Output Leakage Current	0V ≤ V <sub>OUT</sub> ≤ V <sub>CC</sub>			±5	μA
I <sub>CC1</sub>	Active Read Current ( Byte mode)	CE# = V <sub>IL</sub> ; OE# = V <sub>IH</sub> ; f = 5MHZ		9	16	mA
	Active Read Current ( Word mode)			9	16	mA
I <sub>CC2</sub>	Supply Current (Standby-CMOS)	CE# = BYTE# = RESET# = V <sub>CC</sub> ± 0.3V (Note 1)		1	5.0	μA
I <sub>CC3</sub>	Supply Current (Program or Erase)	Byte program, Sector or Chip Erase in progress		20	30	mA
I <sub>CC4</sub>	Reset Current	RESET# = V <sub>SS</sub> ± 0.3V		1	5.0	μA
I <sub>CC5</sub>	Automatic Sleep Mode	V <sub>IH</sub> = V <sub>CC</sub> ± 0.3V V <sub>IL</sub> = V <sub>SS</sub> ± 0.3V		1	5.0	μA
V <sub>IL</sub>	Input Low Voltage		-0.5		0.8	V
V <sub>IH</sub>	Input High Voltage		0.7 x V <sub>CC</sub>		V <sub>CC</sub> ± 0.3	V
V <sub>OL</sub>	Output Low Voltage	I <sub>OL</sub> = 4.0 mA			0.45	V
V <sub>OH</sub>	Output High Voltage CMOS	I <sub>OH</sub> = -100μA	V <sub>CC</sub> - 0.4V			V
V <sub>ID</sub>	A9 Voltage (Electronic Signature)		8.5		9.5	V
I <sub>ID</sub>	A9 Current (Electronic Signature)	A9 = V <sub>ID</sub>			100	μA
V <sub>LKO</sub>	Supply voltage (Erase and Program lock-out)		2.3		2.5	V

**Notes**

1. BYTE# pin can also be GND ± 0.3V. BYTE# and RESET# pin input buffers are always enabled so that they draw power if not at full CMOS supply voltages.

**Test Conditions**

**Test Specifications**

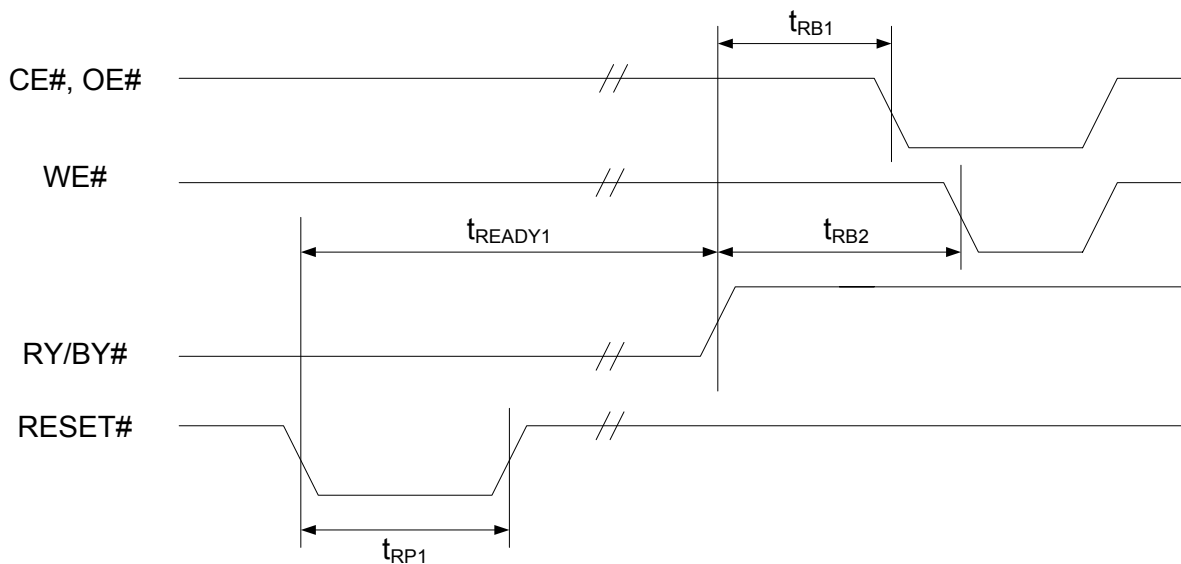
Test Conditions	-70	Unit
Output Load Capacitance, $C_L$	30	pF
Input Rise and Fall times	5	ns
Input Pulse Levels	0.0-3.0	V
Input timing measurement reference levels	1.5	V
Output timing measurement reference levels	1.5	V



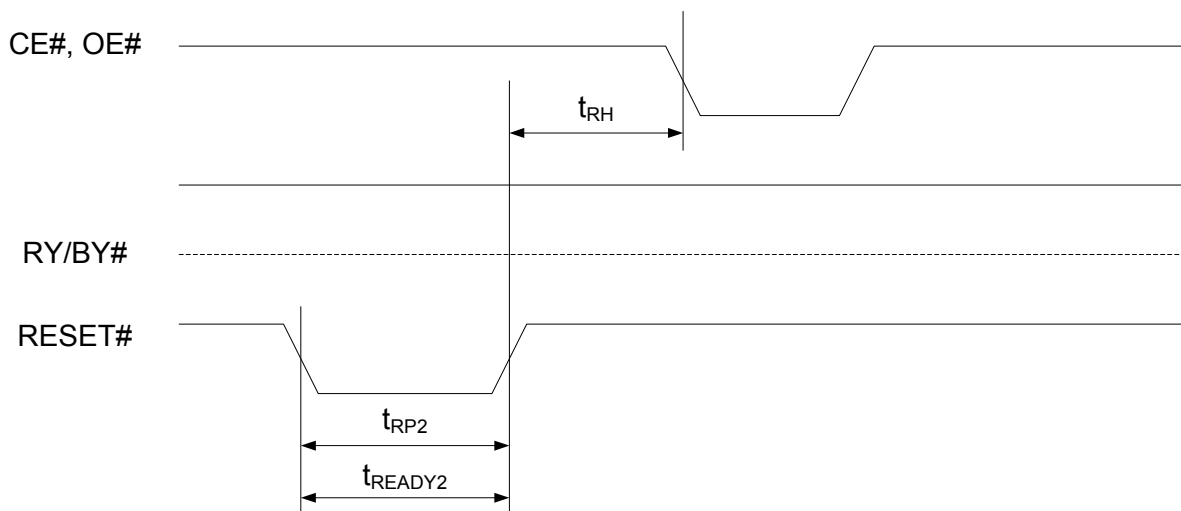
**AC CHARACTERISTICS**  
**Hardware Reset (Reset#)**

Parameter Std	Description	Test Setup	Speed	Unit
			-70	
$t_{RP1}$	RESET# Pulse Width (During Embedded Algorithms)	Min	10	us
$t_{RP2}$	RESET# Pulse Width (NOT During Embedded Algorithms)	Min	500	ns
$t_{RH}$	Reset# High Time Before Read	Min	50	ns
$t_{RB1}$	RY/BY# Recovery Time ( to CE#, OE# go low)	Min	0	ns
$t_{RB2}$	RY/BY# Recovery Time ( to WE# go low)	Min	50	ns
$t_{READY1}$	Reset# Pin Low (During Embedded Algorithms) to Read or Write	Max	20	us
$t_{READY2}$	Reset# Pin Low (NOT During Embedded Algorithms) to Read or Write	Max	500	ns

**Figure 1. AC Waveforms for RESET#**  
**Reset# Timings**



Reset Timing during Embedded Algorithms



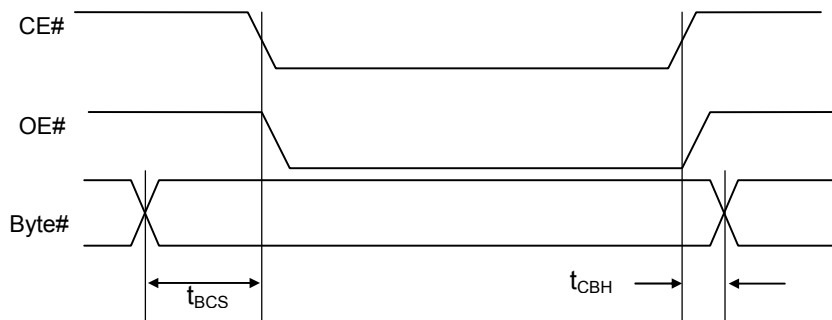
Reset Timing NOT during Embedded Algorithms



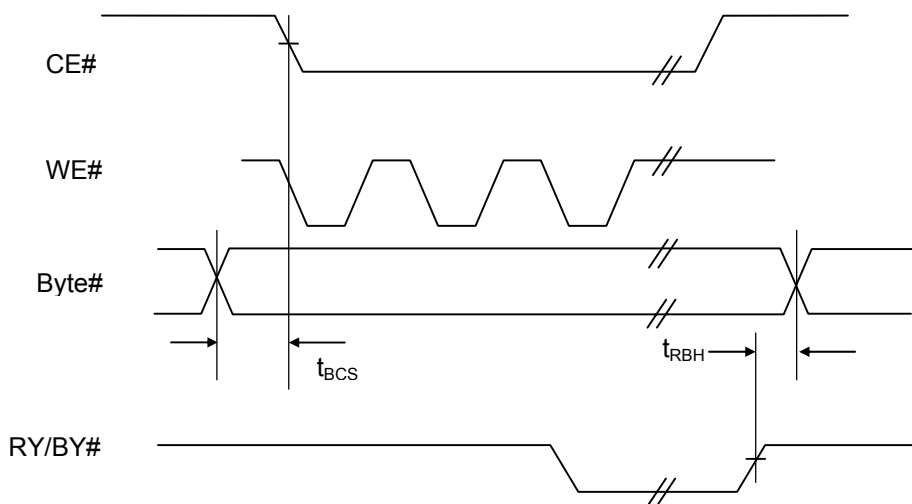
### AC CHARACTERISTICS Word / Byte Configuration (Byte#)

Std Parameter	Description	Test Setup	Speed	Unit
			-70	
t <sub>BCS</sub>	Byte# to CE# switching setup time	Min	0	ns
t <sub>CBH</sub>	CE# to Byte# switching hold time	Min	0	ns
t <sub>RBH</sub>	RY/BY# to Byte# switching hold time	Min	0	ns

Figure 2. AC Waveforms for BYTE#



Byte# timings for Read Operations



Byte #timings for Write Operations

Note: Switching BYTE# pin not allowed during embedded operations



Table 12. AC CHARACTERISTICS

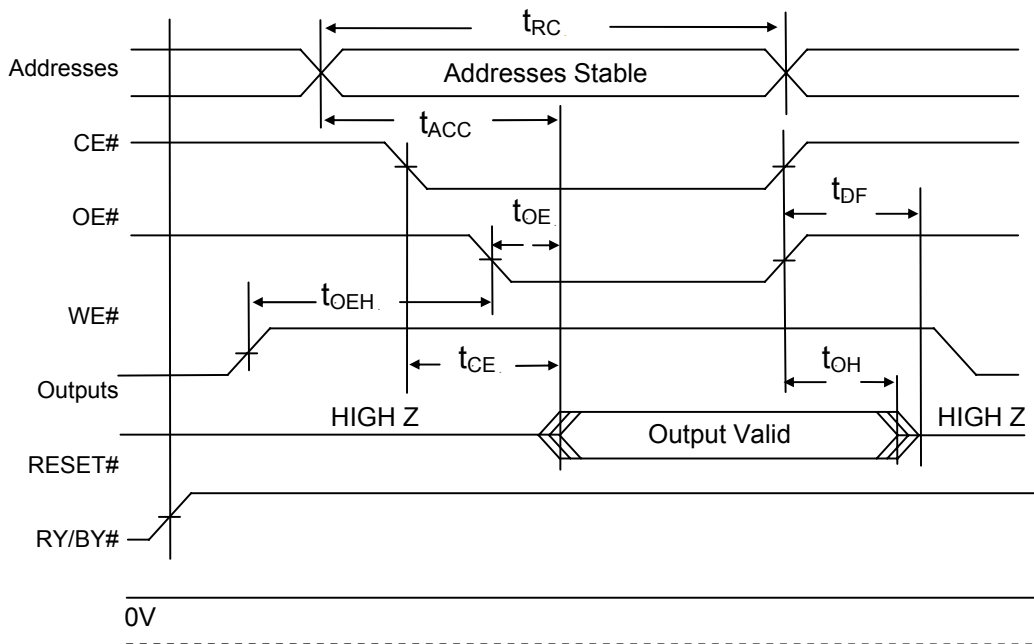
Read-only Operations Characteristics

Parameter Symbols		Description	Test Setup		Speed	Unit
JEDEC	Standard				-70	
$t_{AVAV}$	$t_{RC}$	Read Cycle Time		Min	70	ns
$t_{AVQV}$	$t_{ACC}$	Address to Output Delay	CE# = $V_{IL}$ OE# = $V_{IL}$	Max	70	ns
$t_{ELQV}$	$t_{CE}$	Chip Enable To Output Delay	OE# = $V_{IL}$	Max	70	ns
$t_{GLQV}$	$t_{OE}$	Output Enable to Output Delay		Max	30	ns
$t_{EHQZ}$	$t_{DF}$	Chip Enable to Output High Z		Max	20	ns
$t_{GHQZ}$	$t_{DF}$	Output Enable to Output High Z		Max	20	ns
$t_{AXQX}$	$t_{OH}$	Output Hold Time from Addresses, CE# or OE#, whichever occurs first		Min	0	ns
	$t_{OEH}$	Output Enable Hold Time	Read	Min	0	ns
			Toggle and DATA# Polling	Min	10	ns

Notes:

- 1. High Z is Not 100% tested.
- 2. For -70
  - $V_{CC} = 2.7V - 3.6V$
  - Output Load : 30pF
  - Input Rise and Fall Times: 5ns
  - Input Rise Levels: 0.0 V to 3.0 V
  - Timing Measurement Reference Level, Input and Output: 1.5 V

Figure 3. AC Waveforms for READ Operations





**Table 13. AC CHARACTERISTICS**

**Write (Erase/Program) Operations**

Parameter Symbols		Description		Speed	Unit	
JEDEC	Standard			-70		
t <sub>AVAV</sub>	t <sub>WC</sub>	Write Cycle Time (Note 1)	Min	70	ns	
t <sub>AVWL</sub>	t <sub>AS</sub>	Address Setup Time	Min	0	ns	
t <sub>WLAX</sub>	t <sub>AH</sub>	Address Hold Time	Min	45	ns	
t <sub>DVWH</sub>	t <sub>DS</sub>	Data Setup Time	Min	30	ns	
t <sub>WHDX</sub>	t <sub>DH</sub>	Data Hold Time	Min	0	ns	
	t <sub>OEH</sub>	Output Enable Hold Time	Read	Min	0	ns
			Toggle and DATA# Polling	Min	10	ns
t <sub>GHWL</sub>	t <sub>GHWL</sub>	Read Recovery Time before Write (OE# High to WE# Low)	Min	0	ns	
t <sub>ELWL</sub>	t <sub>CS</sub>	CE# Setup Time	Min	0	ns	
t <sub>WHEH</sub>	t <sub>CH</sub>	CE# Hold Time	Min	0	ns	
t <sub>WLWH</sub>	t <sub>WP</sub>	Write Pulse Width	Min	35	ns	
t <sub>WHDL</sub>	t <sub>WPH</sub>	Write Pulse Width High	Min	20	ns	
t <sub>WHWH1</sub>	t <sub>WHWH1</sub>	Programming Operation (Word AND Byte Mode)	Typ	8	μs	
			Max	200	μs	
t <sub>WHWH2</sub>	t <sub>WHWH2</sub>	Erase Operation (Note 2)	Sector	Typ	0.1	s
			Chip	Max	4	s
	t <sub>VCS</sub>	Vcc Setup Time	Min	50	μs	
	t <sub>BUSY</sub>	WE# High to RY/BY# Low	Max	70	ns	
	t <sub>RB</sub>	Recovery Time from RY/BY#	Min	0	ns	

1. Not 100% tested.
2. See Erase and Programming Performance for more information.



**Table 14. AC CHARACTERISTICS**

**Write (Erase/Program) Operations**

**Alternate CE# Controlled Writes**

Parameter Symbols		Description		Speed	Unit	
JEDEC	Standard			-70		
t <sub>AVAV</sub>	t <sub>WC</sub>	Write Cycle Time (Note 1)	Min	70	ns	
t <sub>AVEL</sub>	t <sub>AS</sub>	Address Setup Time	Min	0	ns	
t <sub>ELAX</sub>	t <sub>AH</sub>	Address Hold Time	Min	45	ns	
t <sub>DVEH</sub>	t <sub>DS</sub>	Data Setup Time	Min	30	ns	
t <sub>EHDX</sub>	t <sub>DH</sub>	Data Hold Time	Min	0	ns	
	t <sub>OES</sub>	Output Enable Setup Time	Min	0	ns	
	t <sub>OEH</sub>	Output Enable Hold Time	Read	Min	0	ns
			Toggle and Data Polling	Min	10	ns
t <sub>GHEL</sub>	t <sub>GHEL</sub>	Read Recovery Time before Write (OE# High to CE# Low)	Min	0	ns	
t <sub>WLEL</sub>	t <sub>WS</sub>	WE# Setup Time	Min	0	ns	
t <sub>EHWH</sub>	t <sub>WH</sub>	WE# Hold Time	Min	0	ns	
t <sub>ELEH</sub>	t <sub>CP</sub>	Write Pulse Width	Min	35	ns	
t <sub>EHEL</sub>	t <sub>CPH</sub>	Write Pulse Width High	Min	20	ns	
t <sub>WHWH1</sub>	t <sub>WHWH1</sub>	Programming Operation (Byte AND word mode) (Note 2)	Typ	8	μs	
			Max	200	μs	
t <sub>WHWH2</sub>	t <sub>WHWH2</sub>	Erase Operation (Note 2)	Sector	Typ	0.1	s
			Chip	Typ	4	s
	t <sub>VCS</sub>	Vcc Setup Time	Min	50	μs	
	t <sub>RB</sub>	Recovery Time from RY/BY#	Min	0	ns	

1. Not 100% tested.
2. See Erase and Programming Performance for more information.

**Table 15. ERASE AND PROGRAMMING PERFORMANCE**

Parameter	Limits			Comments
	Typ	Max	Unit	
Sector Erase Time	0.1	2	sec	Excludes 00h programming prior to erasure
Chip Erase Time	4	35	sec	
Byte Programming Time	8	200	μs	Excludes system level overhead
Word Programming Time	8	200	μs	
Chip Programming Time	Byte	16.8	50.4	
	Word	8.4	25.2	
Erase/Program Endurance	100K		cycles	Minimum 100K cycles

**Notes:** Maximum program and erase time assume the following conditions  $V_{CC} = 2.7 V$ ,  $85^{\circ}C$

**Table 16. 48-PIN TSOP PIN CAPACITANCE @ 25°C, 1.0MHz**

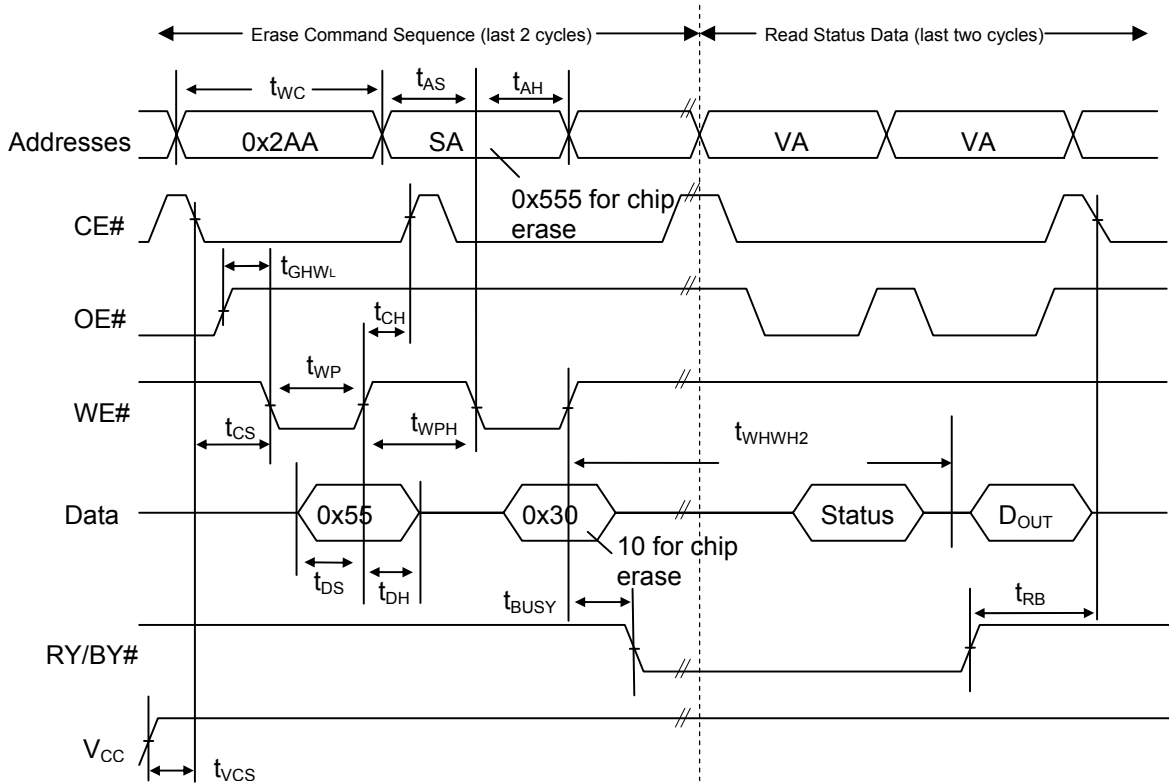
Parameter Symbol	Parameter Description	Test Setup	Typ	Max	Unit
C <sub>IN</sub>	Input Capacitance	$V_{IN} = 0$	6	7.5	pF
C <sub>OUT</sub>	Output Capacitance	$V_{OUT} = 0$	8.5	12	pF
C <sub>IN2</sub>	Control Pin Capacitance	$V_{IN} = 0$	7.5	9	pF

**Table 17. DATA RETENTION**

Parameter Description	Test Conditions	Min	Unit
Data Retention Time	150°C	10	Years
	125°C	20	Years

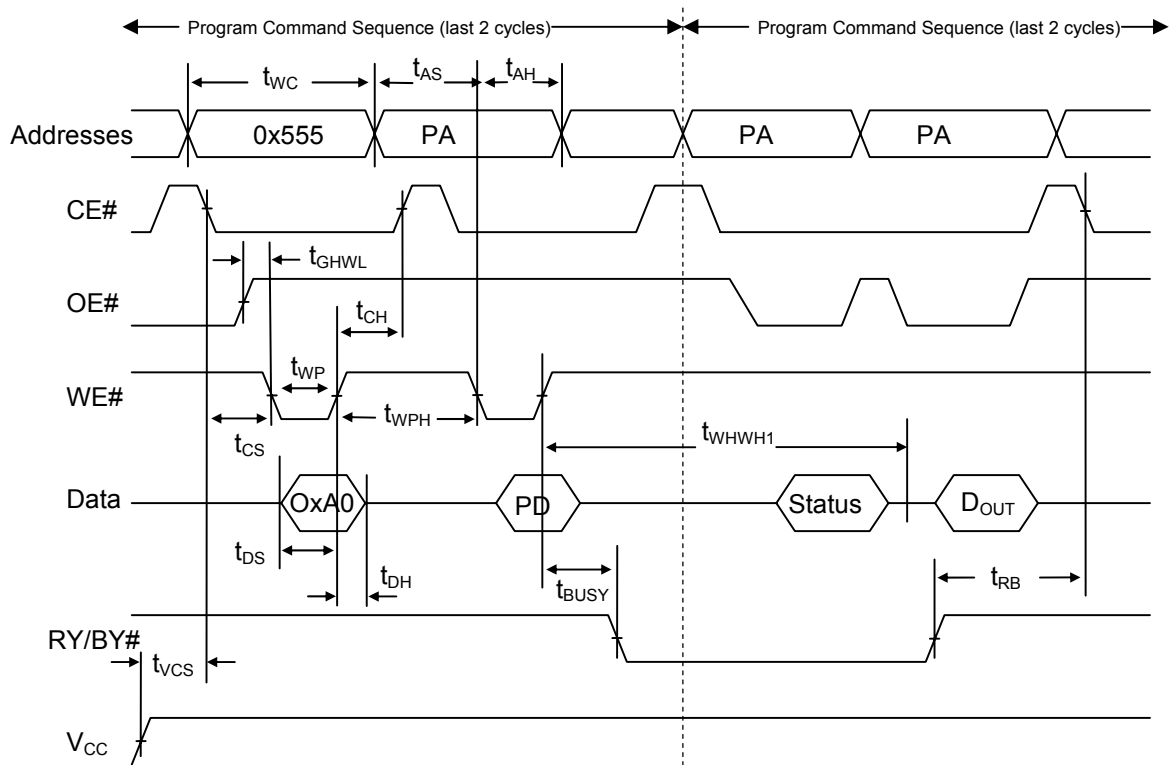
## AC CHARACTERISTICS

**Figure 4. AC Waveforms for Chip/Sector Erase Operations Timings**

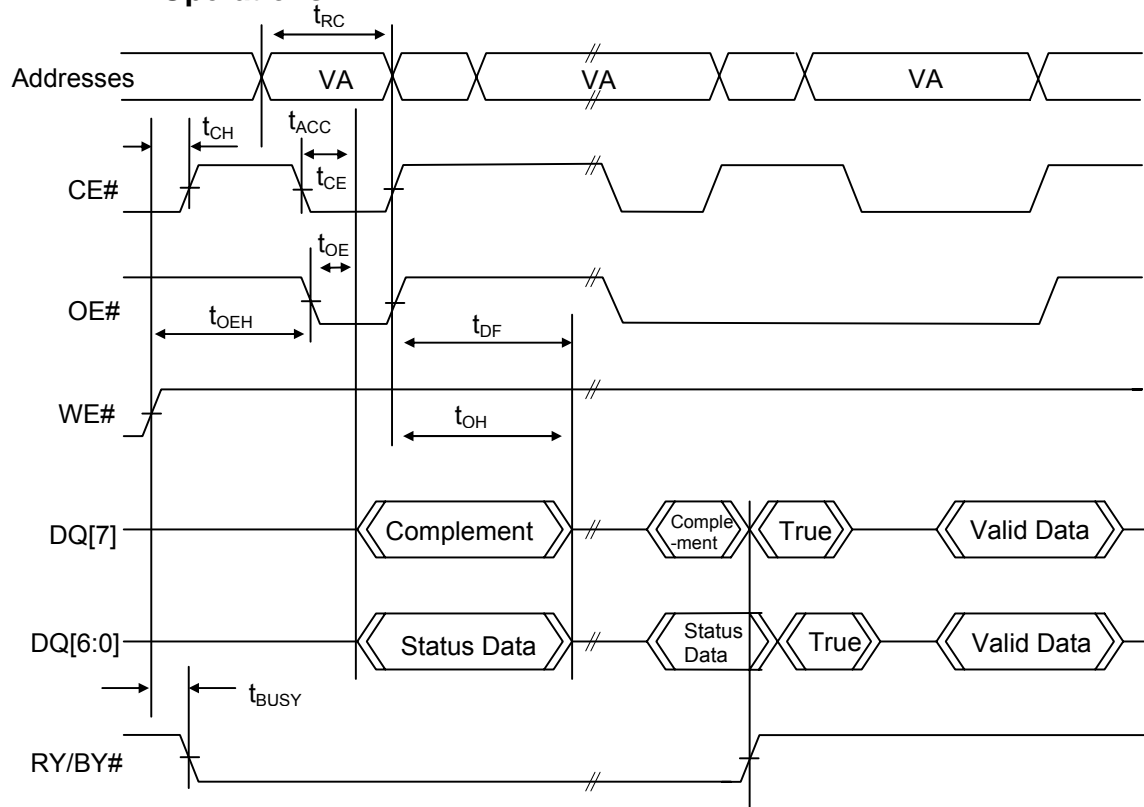


**Notes:**

1. SA=Sector Address (for sector erase), VA=Valid Address for reading status,  $D_{out}$ =true data at read address.
2.  $V_{cc}$  shown only to illustrate  $t_{VCS}$  measurement references. It cannot occur as shown during a valid command sequence.

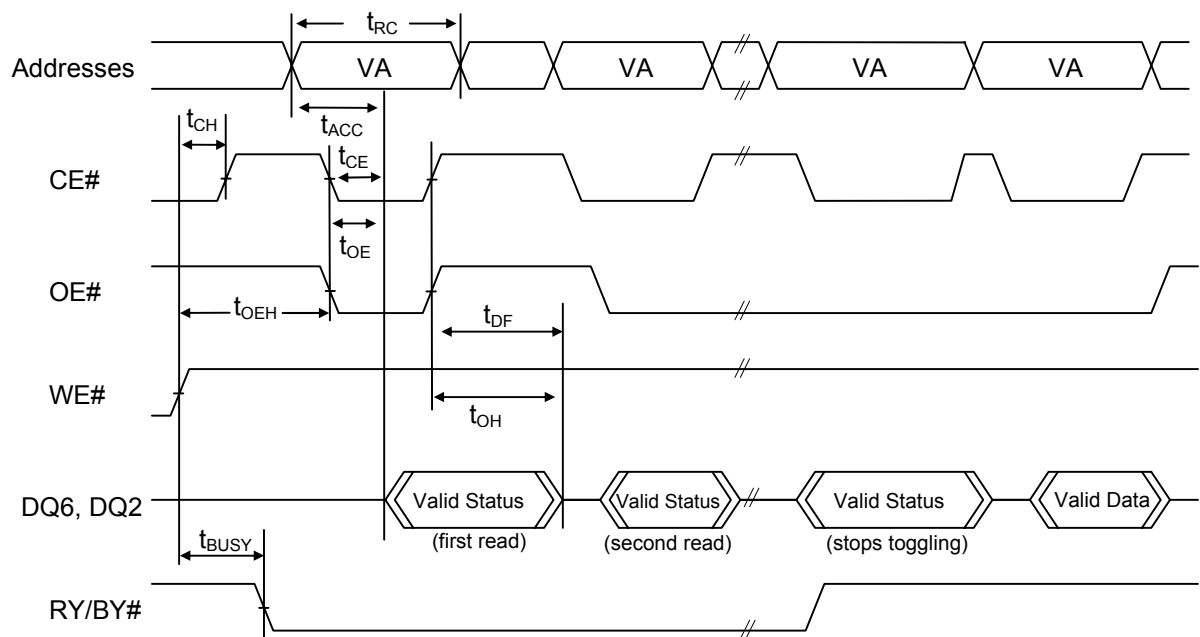
**Figure 5. Program Operation Timings**

**Notes:**

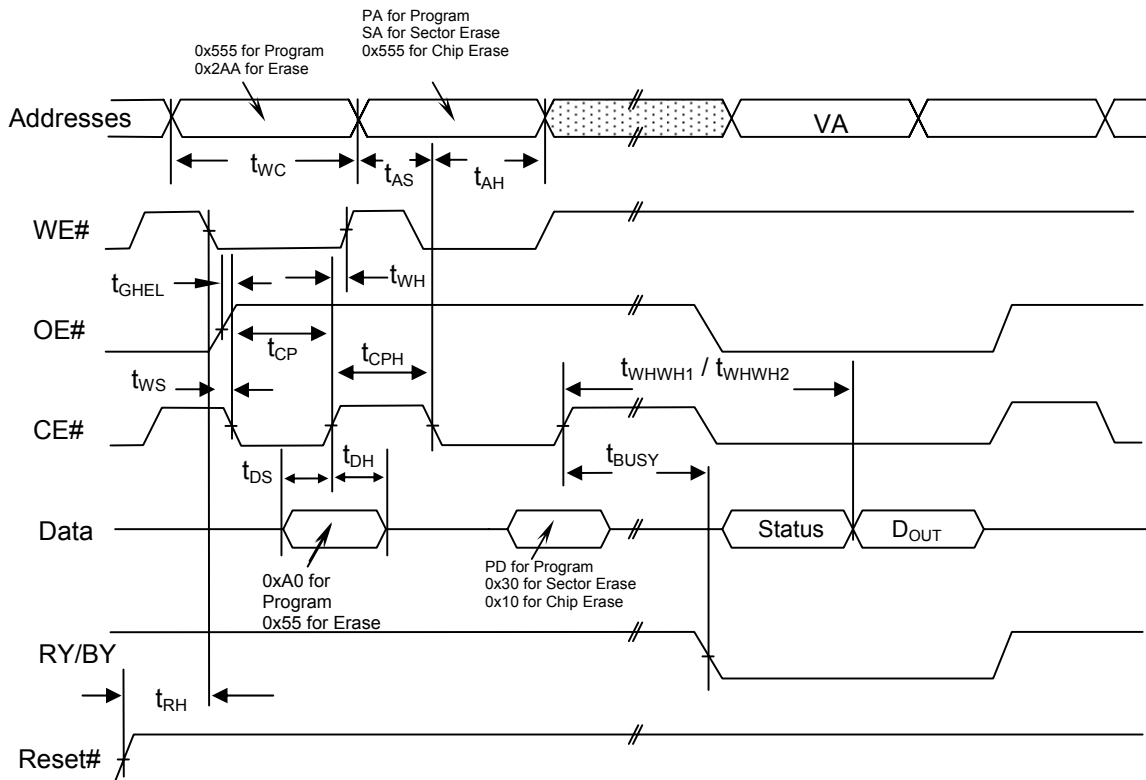
1. PA=Program Address, PD=Program Data, D<sub>OUT</sub> is the true data at the program address.
2. V<sub>CC</sub> shown in order to illustrate t<sub>VCS</sub> measurement references. It cannot occur as shown during a valid command sequence.

**Figure 6. AC Waveforms for /DATA Polling During Embedded Algorithm Operations**


Notes:

1. VA=Valid Address for reading Data# Polling status data
2. This diagram shows the first status cycle after the command sequence, the last status read cycle and the array data read cycle.

**Figure 7. AC Waveforms for Toggle Bit During Embedded Algorithm Operations**


**Figure 8. Alternate CE# Controlled Write Operation Timings**

**Notes:**

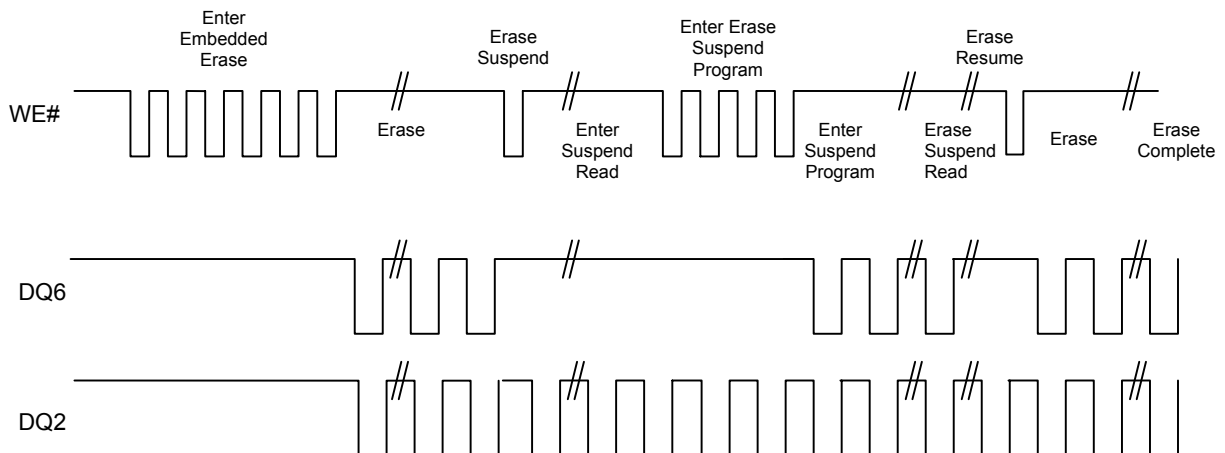
PA = address of the memory location to be programmed.

PD = data to be programmed at byte address.

VA = Valid Address for reading program or erase status

 D<sub>out</sub> = array data read at VA

 Shown above are the last two cycles of the program or erase command sequence and the last status read cycle  
 Reset# shown to illustrate t<sub>RH</sub> measurement references. It cannot occur as shown during a valid command sequence.

**Figure 9. DQ2 vs. DQ6**


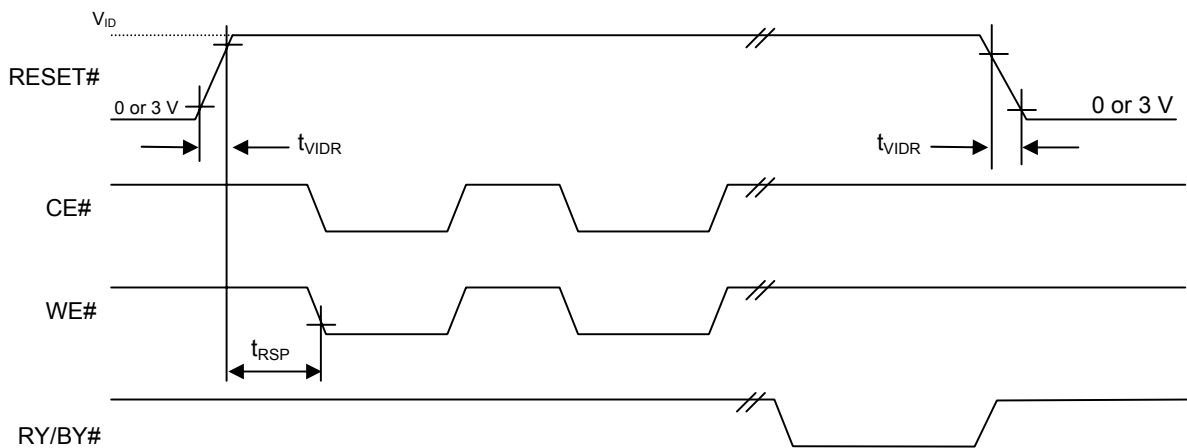


**Table 19. Temporary Sector Unprotect**

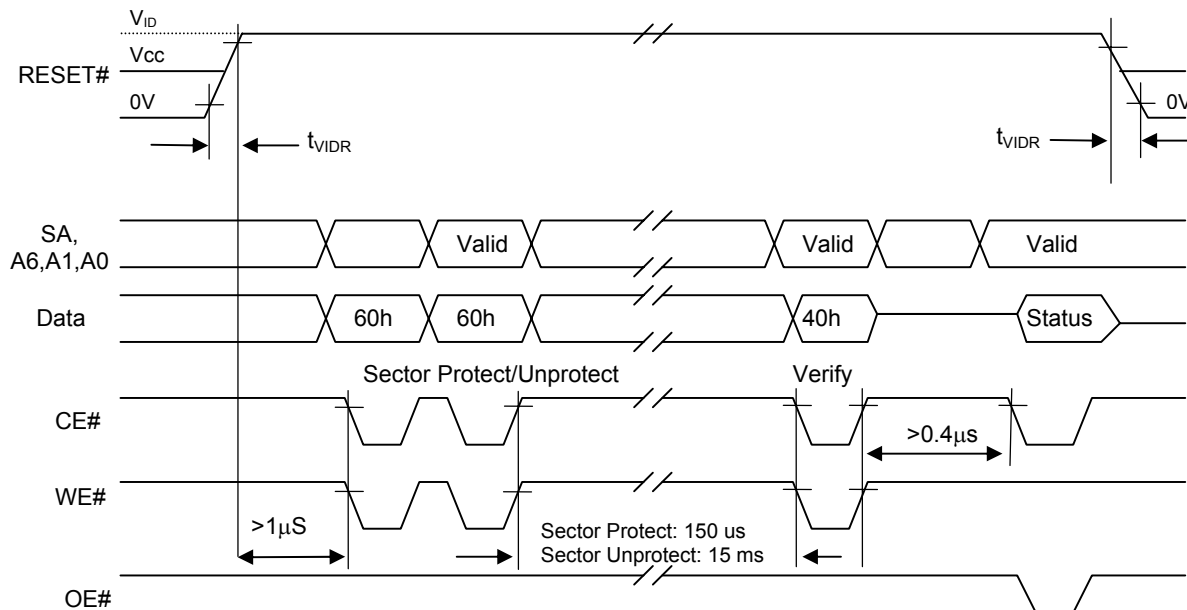
Parameter Std	Description		Speed Option		Unit
			-70		
$t_{VIDR}$	$V_{ID}$ Rise and Fall Time	Min	500		ns
$t_{RSP}$	RESET# Setup Time for Temporary Sector Unprotect	Min	4		$\mu$ s

Notes:  $t_{RSP}$  is Not 100% tested.

**Figure 10. Temporary Sector Unprotect Timing Diagram**

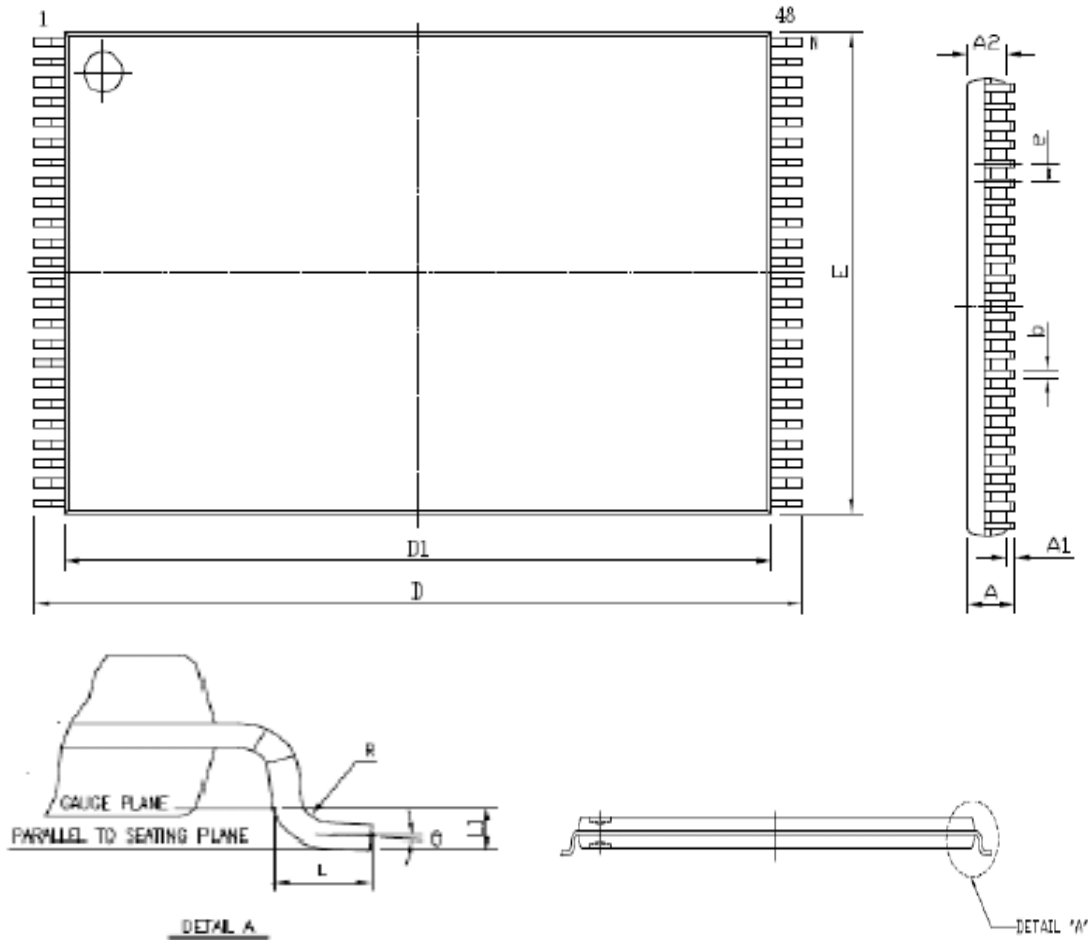


**Figure 11. Sector Protect/Unprotect Timing Diagram**



**Notes:**

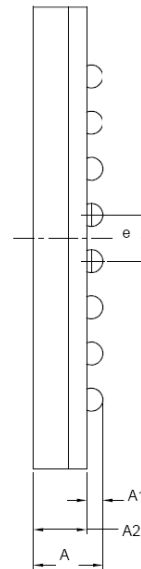
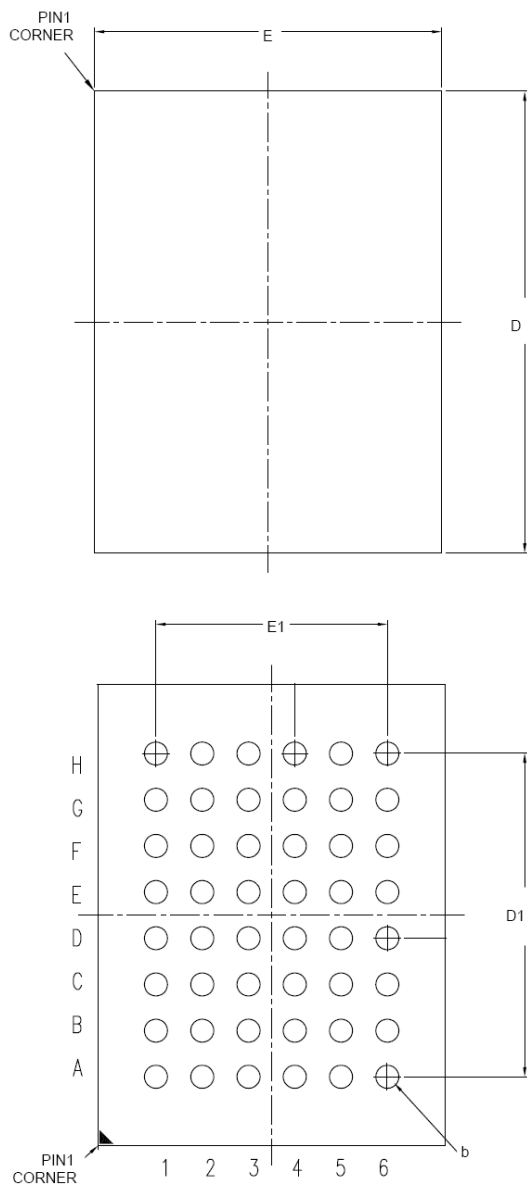
Use standard microprocessor timings for this device for read and write cycles.  
 For Sector Protect, use  $A6=0, A1=1, A0=0$ . For Sector Unprotect, use  $A6=1, A1=1, A0=0$ .

**FIGURE 12. 48L TSOP 12mm x 20mm package outline**


SYMBOL	DIMENSION IN MM		
	MIN.	NOR	MAX
A	---	---	1.20
A1	0.05	---	0.15
A2	0.95	1.00	1.05
D	19.80	20.00	20.20
D1	18.30	18.40	18.50
E	11.9	12.00	12.10
e	---	0.50	---
b	0.17	0.22	0.27
L	0.5	0.60	0.70
L1	---	0.25	---
R	0.08	---	0.20
$\theta$	$0^{\circ}$	$3^{\circ}$	$5^{\circ}$

Note : 1. Coplanarity: 0.1 mm

2. Max. allowable mold flash is 0.15 mm  
at the pkg ends, 0.25 mm between leads.

**FIGURE 13. 48L TFBGA 6mm x 8mm package outline**


SYMBOL	DIMENSION IN MM		
	MIN.	NOR	MAX
A	---	---	1.30
A1	0.23	0.29	0.35
A2	0.84	0.91	0.95
D	7.90	8.00	8.10
E	5.90	6.00	6.10
D1	---	5.60	---
E1	---	4.00	---
e	---	0.80	---
b	0.35	0.40	0.45

**Note : 1. Coplanarity: 0.1 mm**



**ABSOLUTE MAXIMUM RATINGS**

Parameter	Value	Unit	
Storage Temperature	-65 to +150	°C	
Plastic Packages	-65 to +125	°C	
Ambient Temperature With Power Applied	-55 to +125	°C	
Output Short Circuit Current <sup>1</sup>	200	mA	
Voltage with Respect to Ground	A9, OE#, Reset# <sup>2</sup>	-0.5 to +11.5	V
	All other pins <sup>3</sup>	-0.5 to V <sub>cc</sub> +0.5	V
	V <sub>cc</sub>	-0.5 to + 4.0	V

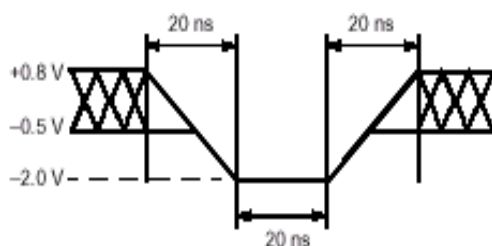
Notes:

1. No more than one output shorted at a time. Duration of the short circuit should not be greater than one second.
2. Minimum DC input voltage on A9, OE#, RESET# pins is -0.5V. During voltage transitions, A9, OE#, RESET# pins may undershoot V<sub>ss</sub> to -1.0V for periods of up to 50ns and to -2.0V for periods of up to 20ns. See figure below. Maximum DC input voltage on A9, OE#, and RESET# is 11.5V which may overshoot to 12.5V for periods up to 20ns.
3. Minimum DC voltage on input or I/O pins is -0.5 V. During voltage transitions, inputs may undershoot V<sub>ss</sub> to -1.0V for periods of up to 50ns and to -2.0 V for periods of up to 20ns. See figure below. Maximum DC voltage on output and I/O pins is V<sub>cc</sub> + 0.5 V. During voltage transitions, outputs may overshoot to V<sub>cc</sub> + 1.5 V for periods up to 20ns. See figure below.
4. Stresses above the values so mentioned above may cause permanent damage to the device. These values are for a stress rating only and do not imply that the device should be operated at conditions up to or above these values. Exposure of the device to the maximum rating values for extended periods of time may adversely affect the device reliability.

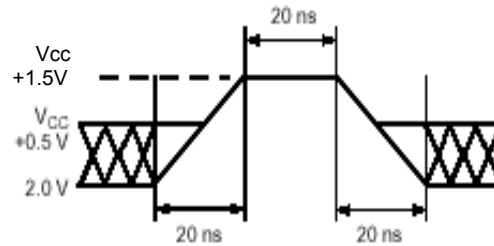
**RECOMMENDED OPERATING RANGES<sup>1</sup>**

Parameter	Value	Unit
Ambient Operating Temperature Industrial Devices	-40 to 85	°C
Operating Supply Voltage V <sub>cc</sub>	Full Voltage Range: 2.7 to 3.6V	V

3. Recommended Operating Ranges define those limits between which the functionality of the device is guaranteed.



Maximum Negative Overshoot Waveform



Maximum Positive Overshoot Waveform



## Purpose

Eon Silicon Solution Inc. (hereinafter called “Eon”) is going to provide its products’ top marking on ICs with < cFeon > from January 1st, 2009, and without any change of the part number and the compositions of the ICs. Eon is still keeping the promise of quality for all the products with the same as that of Eon delivered before. Please be advised with the change and appreciate your kindly cooperation and fully support Eon’s product family.

## Eon products’ New Top Marking

**cFeon**

### cFeon Top Marking Example:

**cFeon**

**Part Number: XXXX-XXX**

**Lot Number: XXXXX**

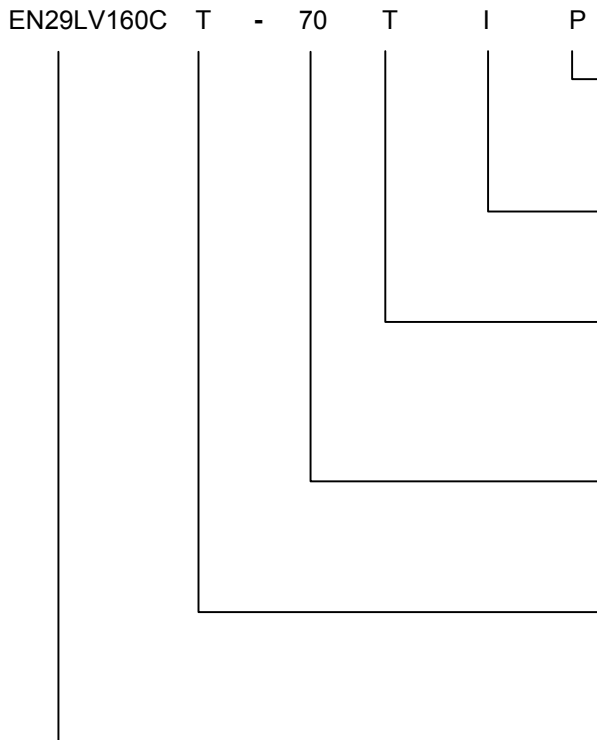
**Date Code: XXXXX**

## For More Information

Please contact your local sales office for additional information about Eon memory solutions.



**ORDERING INFORMATION**



**PACKAGING CONTENT**

P = RoHS compliant

**TEMPERATURE RANGE**

I = Industrial (-40°C to +85°C)

**PACKAGE**

T = 48-pin TSOP

B = 48-Ball Thin Fine Pitch Ball Grid Array (TFBGA)  
0.80mm pitch, 6mm x 8mm package

**SPEED**

70 = 70ns

**BOOT CODE SECTOR ARCHITECTURE**

T = Top boot Sector

B = Bottom boot Sector

**BASE PART NUMBER**

EN = Eon Silicon Solution Inc.

29LV = FLASH, 3V Read Program Erase

160 = 16 Megabit (2M x 8 / 1M x 16)

C = version identifier

**Revisions List**

<b>Revision No</b>	<b>Description</b>	<b>Date</b>
A	Initial Release	2011/01/07
B	1. Update Secured Silicon Sector length from 32 words to 128 words. (The related table 2B and table 2D on page 4 and page 5.) 2. Update V <sub>HH</sub> and V <sub>ID</sub> from 10.5-11.5V to 8.5-9.5V. 3. Update Table 11. DC Characteristics on page 26.	2011/06/09